

Jøtul GF 400 DV IPI Sebago

Direct Vent Gas Stove

Pilot on Demand Ignition

Installation and Operation Instructions

*Certified to ANSI Z21.88-2016 • CSA 2.33-2016
et CAN/CGA 2.17-M17*

INSTALLER: Leave this manual with the appliance.
CONSUMER: Retain this manual for future reference.

WARNING: If the information in these instructions is not followed exactly, a fire or explosion may result causing property damage, personal injury or loss of life.

- Do not store or use gasoline or other flammable vapors and liquids in the vicinity of this or any other appliance.
- **WHAT TO DO IF YOU SMELL GAS**
 - Do not try to light any appliance.
 - Do not touch any electrical switch; do not use any phone in your building.
 - Immediately call your gas supplier from a neighbor's phone. Follow the gas supplier's instructions.
 - If you cannot reach your gas supplier, call the fire department.
- Installation and service must be performed by a qualified installer, service agency or the gas supplier.
- In the Commonwealth of Massachusetts, a carbon monoxide (CO) detector shall be installed in the same room as the appliance.

This appliance may be installed in an aftermarket, permanently located, manufactured home or mobile home, where not prohibited by local codes.

This appliance is only for use with the types of gas indicated on the rating plate. A conversion kit is supplied with the appliance.

⚠ DANGER



**HOT GLASS WILL
CAUSE BURNS.**

**DO NOT TOUCH GLASS
UNTIL COOLED.**

**NEVER ALLOW CHILDREN
TO TOUCH GLASS.**

A barrier designed to reduce the burn hazard from the glass viewing area is provided with this appliance and shall be installed for the protection of children and other at-risk individuals.

THIS OWNER'S MANUAL PROVIDES INFORMATION TO ENSURE SAFE INSTALLATION AND EFFICIENT, DEPENDABLE OPERATION OF YOUR FIREPLACE INSERT. PLEASE READ THESE INSTRUCTIONS IN THEIR ENTIRETY AND MAKE THEM AVAILABLE TO ANYONE USING OR SERVICING THIS GAS INSERT.

DO NOT ATTEMPT TO ALTER OR MODIFY THE CONSTRUCTION OF THIS APPLIANCE OR ITS COMPONENTS. ANY MODIFICATION OR ALTERATION WILL VOID THE WARRANTY, CERTIFICATION AND LISTING OF THIS APPLIANCE.

THIS HEATER MUST BE INSTALLED AND MAINTAINED BY A QUALIFIED SERVICE AGENCY.

Suggested Tools for Installation and Service

- External regulator (for Propane only)
- Piping which complies with local code
- Manual shut-off valve - T-Handle required in Massachusetts
- Sediment trap - if required by code
- Tee joint
- Pipe wrench
- Pipe sealant
- 10 mm open end wrench
- 1/2", 7/16" open end wrench
- Phillips head screwdriver
- Flat head screwdriver
- 1/4" nut driver
- Gloves
- Safety glasses
- Torx T-20 screwdriver
- Tin snips

PLEASE NOTE:

Initial Break-in

It is normal for smoke and odor to occur during the initial stages of operation, depending upon temperatures generated over time. This "curing" condition can be alleviated by promoting fresh air circulation within the immediate vicinity of the appliance.

Operation Sound

Please be aware that cast iron and steel components expand and contract with temperature fluctuations that are often accompanied by "creaking" or "pinging" sounds.

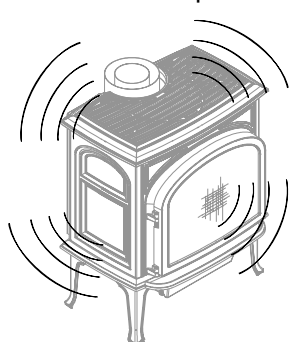

This is the result of natural thermal activity.

The optional blower fan will also generate a slight hum at the low setting and progressively increase with the velocity of forced air.

Installation Requirements for the Commonwealth of Massachusetts

THIS PRODUCT MUST BE INSTALLED BY A LICENSED MASTER OR JOURNEYMAN PLUMBER OR GAS-FITTER WHEN INSTALLED IN THE COMMONWEALTH OF MASSACHUSETTS.

1. If there is not one already present, on each floor level where there are bedroom(s), a carbon monoxide detector and alarm shall be placed in the living area outside the bedroom(s). The carbon monoxide detector shall comply with NFPA 720 (2005 Edition).
2. A carbon monoxide detector shall:
 - a) Be located in the room that houses the appliance or equipment;
 - b) Be either hard-wired or battery powered or both; and
 - c) Shall comply with NFPA 720 (2005 Edition).
3. A Product-approved vent terminal must be used, and if applicable, a Product-approved air intake must be used. Installation shall be in strict compliance with the manufacturer's instructions. A copy of the installation instructions must remain with the appliance or equipment at the completion of the installation.

NATIONAL FIREPLACE INSTITUTE



CERTIFIED
www.nficertified.org

We recommend that our gas products be installed and serviced by professionals who are certified in the U.S. by the National Fireplace Institute® (NFI) as NFI Gas Specialists.

Canada

ENERGUIDE

Gas Fireplace Energy Efficiency Rating

Natural Gas / 68.19%
Propane / 67.69%

Based on CSA P.4.1-15

Model No. Jøtul GF 400 DV IPI



Table of Contents

- Service Tools 2
- Specifications 4
- General Information 4
- Unpacking Your Stove 5
- Safety Information 5
- Installation Requirements
 - Location 6
 - Hearth Protection 6
 - Clearances 6
 - Mantel & Trim 7
 - Alcove 7
- Vent Requirements 8
 - Adding Restriction 8
 - Termination Matrix 9
 - Vertical Termination 10
 - Horizontal Termination 12
 - Vent Terminal Clearances 14
- Mobile Home Installation 15
- Fuel Conversion 15
- Gas Connection 17
- Gas Pressure 18
- High Altitude Adjustment 18
- Optional Brick Panel Installation 19
- Log Set Installation 20
- Optional Wall Thermostat 21
- System Check 22
- Flame Picture Adjustment 23
- Manual Operation 24
- Maintenance 25
 - Glass Replacement 25
- Optional Premium Upgrade Kits
 - Flame Control 26
 - Accent Lamp 26
 - Blower & Multifunction Remote 27
- Remote Operation 28
- Wiring Diagram 32
- Illustrated Parts Lists 33-36
- Accessory Listing 36
- Appendix 37
- Warranty Statement 38
- Lighting Instructions 39

Jøtul GF 400 DV IPI Sebago (POD)

Manufactured and Distributed by:
Jøtul North America
55 Hutcherson Dr.
Gorham, Maine 04038

Certified Test Standards

This appliance complies with National Safety standards and is tested and listed by Intertek Testing Services of Middleton, Wisconsin to ANSI Z21.88-2016 • CSA 2.33-2016, “Vented Gas Fireplace Heater” and CAN/CGA 2.17-M17.

Your stove has a unique serial number stamped on the rating plate which is hung on the back. Please record the serial number in the space below. You may also wish to attach your purchase receipt to this page for future reference.

MODEL NAME: Jøtul GF 400 DV IPI Sebago Gas Stove

SERIAL NUMBER: _____

DATE OF PURCHASE: _____

AUTHORIZED DEALER: _____

ADDRESS _____

PHONE: _____

INSTALLER: _____

FUEL TYPE: _____

FUEL CONVERSION: NO _____ YES _____

NOTES: _____

GF 400 DV IPI Sebago Specifications

Input Rates

Natural Gas

32,000 BTU/hr. maximum input
17,000 BTU/hr. minimum input

Propane

30,000 BTU/hr. maximum input
14,000 BTU/hr. minimum input

Inlet Pressure:	MIN	MAX
Natural Gas:	5.0 WC (1.24 kPa)	7.0 WC (1.74 kPa)
Propane:	12.0 WC (2.90 kPa)	14.0 WC (3.48 kPa)

Manifold Pressure:	MIN	MAX
Natural Gas:	1.1 WC (.27 kPa)	3.80 WC (.95 kPa)
Propane:	2.9 WC (.72 kPa)	11.0 WC (2.74 kPa)

- SIT Pro Flame 2 Intermitent Pilot Ignition - 120V / 60 Hz
- Steady State Efficiency: 76.60% NG / 77.02% LP
- AFUE Efficiency: 69.27% NG / 69.45% LP
- CSA P4.1-15 Fireplace Efficiency:
NG - 67.70% LP - 66.91%
- Factory Air Shutter Settings: NG - 1/16" LP - 1/4"
- Continuous Pilot Ignition Mode (CPI) may also be used
- Power Requirement: 120 VAC, 4 amps for IFC Module, optional Blower and Accent Lamp.
Back-up Battery Pack: 4, AA - 1.5V
- Remote Control Transmitter batteries: 3, AAA - 1.5V
- Ambient Temperature Range: 32 -122°F (0 - 50°C)
- Remote Radio Frequency: 315 MHz

General Information

- **THIS HEATER MUST BE INSTALLED AND MAINTAINED BY A QUALIFIED SERVICE AGENCY.**
- The installation and repair of this appliance must be done by a qualified service person. Failure to properly install and maintain this heater could result in an unsafe or hazardous installation, which may result in a fire, explosion, property damage, personal injury or loss of life.
- This appliance should be inspected before use and at least annually. More frequent cleaning may be required due to excessive lint from carpeting, bedding material, etc. It is imperative that control compartments, burners, and circulating air passageways of the appliance be kept clean. See Maintenance, page 26, for details.
- **THIS APPLIANCE MUST NOT BE CONNECTED TO A CHIMNEY OR FLUE SERVING ANY OTHER APPLIANCE.**
- The installation must conform to local codes. Your local Jøtul dealer can assist you in determining what is required in your area for a safe and legal installation. Some areas require a permit to install a gas burning appliance. Always consult your local building inspector, or authority having jurisdiction, to determine what regulations apply in your area.
- **CODE COMPLIANCE :** Your local officials have final authority in determining if a proposed installation is acceptable. Any requirement that is requested by the local authority having jurisdiction, that is not specifically addressed in this manual, defaults to local code. In the absence of local codes, the installation requirements must comply with the current edition of National codes. In the U.S., these requirements are established in the National Fuel Code, ANSI Z223.1.(NFPA 54) current edition. In Canada, the codes have been established in CAN/CGA B149 Fuel Installation Code, current edition..

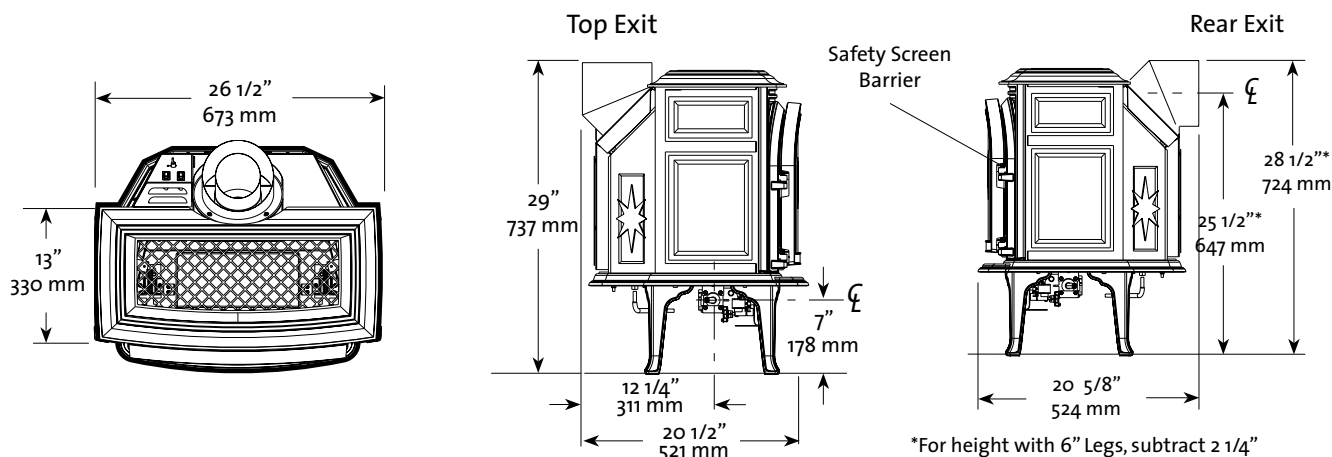

- **DO NOT OPERATE THIS STOVE IF ANY PART HAS BEEN UNDER WATER.** Call a qualified service technician to inspect the heater and to replace any part of the control system and any gas control which may have been under water.

Glass Panel

Do not operate this appliance with the glass front removed, cracked, or broken. Replacement of the glass should be done by a licensed or qualified service person. Only remove glass for routine service. Always handle glass carefully.

Unpacking your stove

1. SAFETY BARRIER SCREEN:

This appliance is equipped with a Certified Barrier Screen that must be installed before operating the unit. The barrier is secured to the stove shipping pallet. Remove those two screws and use pliers to break off each entire perforated section from both screen frame attachment brackets as shown here in grey.

- Remove the Top Plate of the stove by simply lifting it straight off of the stove body.
- To open the firebox, disengage the two Glass Frame Latches located on top of the firebox. Pull each handle forward to clear the latch from the notch in the frame.
- Install the backup batteries before connecting the stove to power. Access the battery box from behind the right side of the control compartment. See fig. 45 on page 25. Disengage the box from the hook & loop tape and press to open the tray.
- Familiarize yourself with the installation requirements specified in this manual, before beginning the installation.

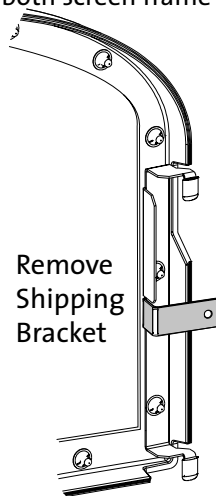

Safety Information

- Due to the high operating temperatures this appliance should be located out of traffic and away from furniture and draperies. Maintain proper clearance to combustible mantels and fireplace trim.
- Children and adults should be alerted to the hazards of high surface temperatures and should stay away to avoid burns or clothing ignition.
- Young children should be supervised while they are in the same room as the appliance. Toddlers, young children and others may be susceptible to accidental contact burns. A physical barrier, such as a child guard, is recommended to be used if there are at-risk individuals in the house. To restrict access to a fireplace or stove, install an adjustable safety gate to keep toddlers, young children and other at-risk individuals out of the room and away from hot surfaces.
- A barrier designed to reduce the risk of burns from the hot viewing glass is provided with this appliance and shall be installed for the protection of children and other at-risk individuals.
- If the barrier becomes damaged, the barrier shall be replaced with the manufacturer's barrier for this appliance. See fig. 72, page 34 for part numbers.
- Any safety screen, guard, or barrier removed for servicing an appliance must be replaced prior to operating the appliance.
- Clothing or other flammable materials should not be placed on or near the fireplace.
- Never allow anyone to use the fireplace if they are unfamiliar with its operation.
- NEVER store or use gasoline or any other flammable vapors or liquids in the vicinity of this appliance.
- Never burn any solid materials (wood, cardboard, paper, coal, etc.) in this appliance. Use with natural gas or propane fuel ONLY.
- Do not slam or strike the glass panel.
- This appliance is NOT for use with aftermarket glass doors.
- Wear gloves and safety glasses while installing or performing maintenance procedures on this appliance.

Hardware Bag Contents

- Fuel Conversion Kit - LP 157611
- Rock Wool , 1 oz. 157259
- Snorkel Plate, Burner Skirt 225030
- 1.5v AAA Batteries, 4

Location

In selecting a location for the stove, consider the following points:

- 1) Heat distribution
- 2) Vent termination requirements
- 3) Gas supply line routing
- 4) Traffic areas, furniture, draperies, etc.

The GF 400 DV IPI may be located on or near conventional construction materials, however, proper clearance to combustibles must be maintained in order to provide adequate air circulation around the appliance. Also, it is important to provide adequate access around the stove for servicing and proper operation.

The clearance and hearth specifications listed in this manual are the minimum requirements for combustible material. A combustible material is anything that can burn (i.e. sheet rock, wall paper, wood, fabrics etc.). These surfaces are not limited to those that are visible and also include materials that may be located behind non-combustibles.

If you are not sure of the combustible nature of a material, consult your local fire officials. Remember, "Fire Resistant" materials are considered combustible: they are difficult to ignite, but will burn. Also, "fire-rated" sheet rock is considered combustible.

Hearth Requirements

This appliance CANNOT be installed directly on carpeting, vinyl, linoleum or wood laminate flooring, such as Pergo®.

If this appliance will be installed on any combustible material OTHER THAN WOOD, a floor pad must be installed that is either metal, wood, ceramic tile, stone, or a listed hearth pad. This floor protection must extend the full width and depth of the appliance. It is not necessary to remove carpeting, vinyl or linoleum from underneath the floor protection. See fig. 1.

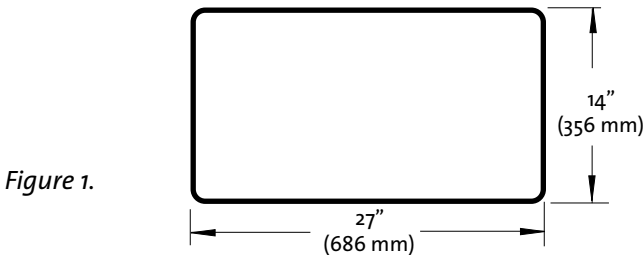

Figure 1.

Stove and Vent Clearance Requirements

The clearances specified and diagrammed here are established from the stove body. The safety barrier has no effect on clearances to combustible material.

Minimum Clearances from the Stove to Combustibles:

See figs. 2-4.

- Rear: 2" (51 mm)
- Ceiling: 32 1/4" (819 mm)
- Corner: 2" (51 mm)
- Sides: 3" (76 mm)

Minimum Clearances from the Vent Pipe to Combustibles:

Horizontal Run:

- Off the top of the pipe 2" (51 mm)
- Off the sides and bottom 1" (25 mm)

Vertical Run:

- All sides 1" (25 mm)

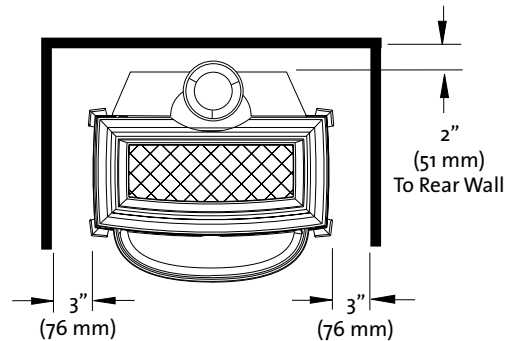

Figure 2. Parallel Installation Clearances.

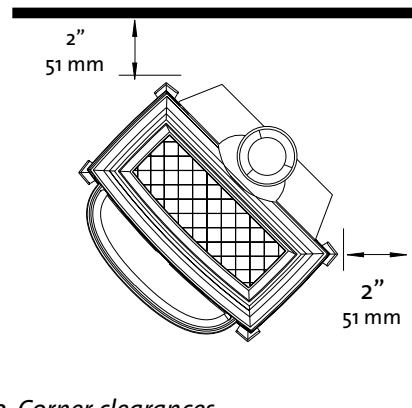

Figure 3. Corner clearances.

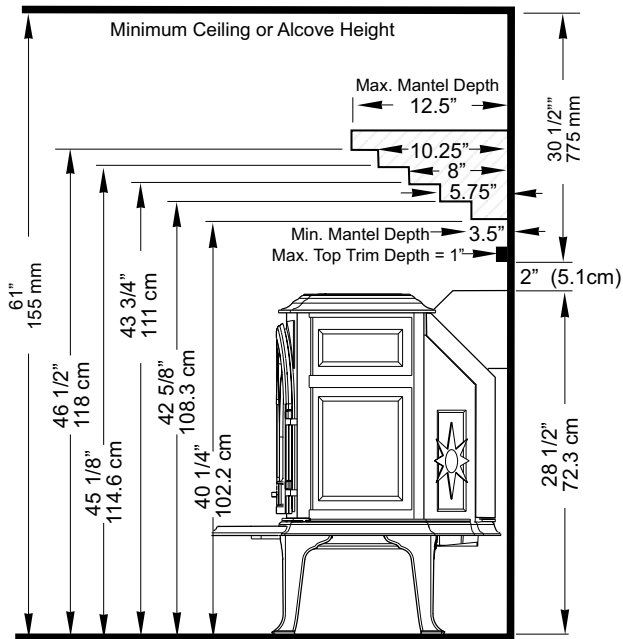

Figure 4. Mantel clearances with standard legs. Reduce stove height and clearance dimensions by 2 1/4 inches with optional Short Legs installed.

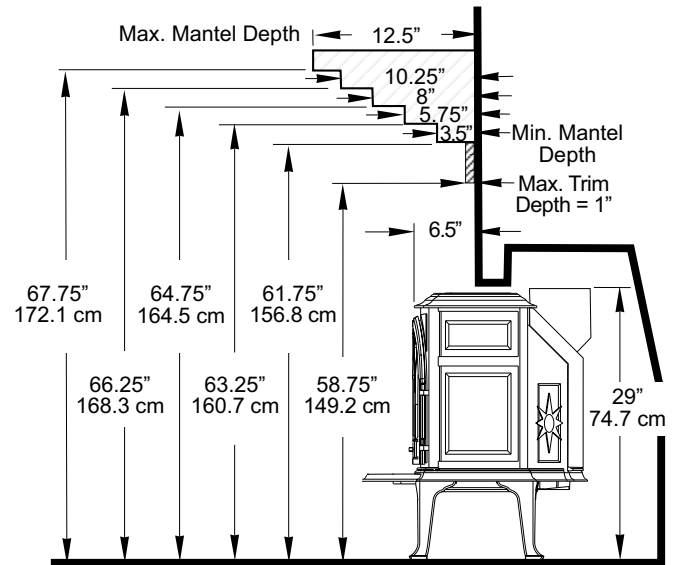

Figure 5. Stove is installed recessed half-way into fireplace. Top plate extends 6.5" forward of the fireplace face.

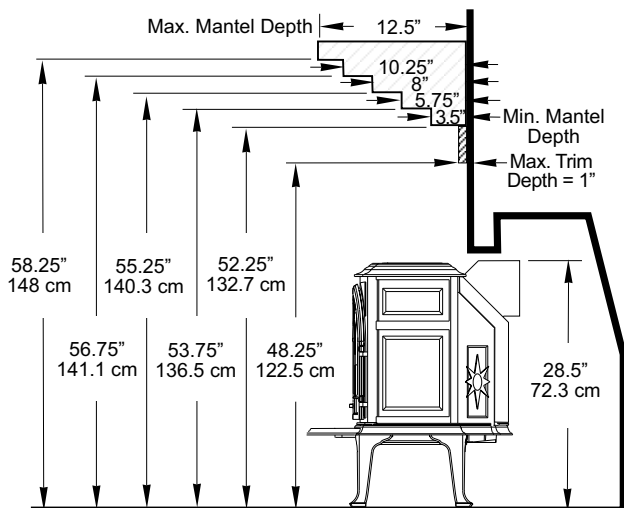

Figure 6. Stove is installed with the top plate flush with the fireplace face.

Alcove Installation

Maximum Alcove Depth:	24" (61 cm)
Minimum Alcove Width:	31 3/4" (80.6 cm)
Minimum Ceiling Height from floor:	61" (155 cm)
With Short Legs (6") :	59" (150 cm)

Alcove dimensions result from specific test configurations, not stove clearance specifications.

Venting Requirements

The Jøtul GF 400 DV IPI gas stove requires 4" x 6 5/8" coaxial, direct vent pipe components and may be installed with a vertical or horizontal termination. Vent installation must conform to the configuration requirements described herein.

This appliance is approved for use with vent systems from the following manufacturers:

- M&G DuraVent, Inc. (Direct Vent Pro Series)
- American Metal Products (Amerivent)
- Security Chimneys International, Ltd. (Secure Vent)
- Selkirk Metalbestos (Direct Temp)
- Metal-Fab, Inc. (Sure-Seal Direct Vent)
- Industrial Chimney Corp. (ExcelDirect)
- Bernard Dalsin Manufacturing (Pro Form)
- Olympia Chimney Supply, Inc. (Ventis Direct Vent)

Use parts of one manufacturer only - DO NOT MIX VENT COMPONENTS FROM DIFFERENT MANUFACTURERS IN THE SAME SYSTEM.

Installation of any components not manufactured or approved by Jøtul or failure to meet all clearance requirements will void all warranties and could result in property damage, bodily injury, or serious fire.

The approved vent configurations described in this manual are derived from extensive testing under controlled laboratory conditions. Gas appliance performance can be negatively affected by variables present in the installation environment, i.e.: atmospheric pressure, strong prevailing winds, adjacent structures and trees, snow accumulation, etc. These conditions should be taken into consideration by the installer and stove owner when planning the vent system design.

IMPORTANT

- **JOINT SEALING REQUIREMENT: APPLY A 1/8" BEAD OF HIGH-TEMPERATURE SEALANT OR MIL-PAC® TO THE MALE SECTION OF THE INNER VENT PIPE. THE CEMENT SHOULD FORM A SEAL BETWEEN THE INNER AND OUTER PIPES. DO NOT USE SILICONE SEALANT.**
- NEVER MODIFY ANY VENTING COMPONENT, OR USE ANY DAMAGED VENTING PRODUCT.
- THE GAS APPLIANCE AND VENT SYSTEM MUST BE VENTED DIRECTLY TO THE OUTSIDE OF THE BUILDING AND NEVER ATTACHED TO A CHIMNEY SERVING A SOLID FUEL OR GAS BURNING APPLIANCE. EACH DIRECT VENT GAS APPLIANCE MUST HAVE ITS OWN SEPARATE VENT SYSTEM. COMMON VENT SYSTEMS ARE PROHIBITED.

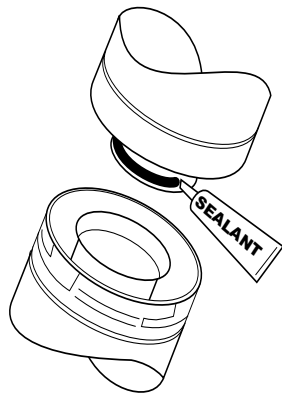

Figure 7.

- IF VENTING SYSTEM IS DISASSEMBLED FOR ANY REASON, REINSTALL PER THE INSTRUCTIONS PROVIDED FOR THE INITIAL INSTALLATION.

Vent Restriction

The GF 400 DV IPI is equipped with an Exhaust Restrictor Plate which enables regulation of exhaust gas flow. The plate prevents overly strong draft that can cause poor combustion and weak flame picture. **Follow the guidelines below, and on the following pages, to determine the correct restrictor plate setting for your particular installation configuration.**

Exhaust Restrictor

The Exhaust Restrictor is an adjustable valve located within the vent outlet. It is set in the FULLY OPEN position at the factory. See Fig. 8. The five positions correlate to the termination zones (A,B,C,D, E) diagramed in figure 9. Use the diagram to determine the setting you should use.

Adjusting Exhaust Restrictor Plate:

1. Lift the Top Plate from the stove.
2. Loosen the locking screw and adjust the pivot plate to the appropriate restriction setting that correlates to the vent configuration.
3. Tighten the lock nut and replace the Top Plate.

NOTE:

Over-restriction of the appliance may cause cold-start problems. The flame picture may appear weak (ghosting) or the pilot may extinguish. Should this condition occur, reduce restriction slightly until the unit functions properly from a cold start. If more restriction is desired, it may be necessary to operate the unit in CPI (continuous pilot) mode in order to maintain adequate flue draft.

Approved Horizontal and Vertical Vent Terminations

See Fig. 9, Vent Termination Matrix

- ALL VENTING MUST TERMINATE (END) WITHIN ONE OF THE SHADED AREAS.
- SET STOVE EXHAUST RESTRICTOR TO THE POSITION THAT CORRESPONDS TO THE VENT TERMINATION AREA IN THE MATRIX. When termination is exactly on a division line, use the less restrictive position. For example, if termination is at 18 ft. / 8 ft., restriction should be set at Position C.
- Up to four 45° or two 90° elbows are permitted in addition to the starter elbow. See NOTE, fig. 9.
- NOTE: Long vent runs (over 12 ft.) in uninsulated air space may require operation in CPI mode for best performance.

Figure 8. Exhaust restrictor positions - viewed from front with top plate removed.

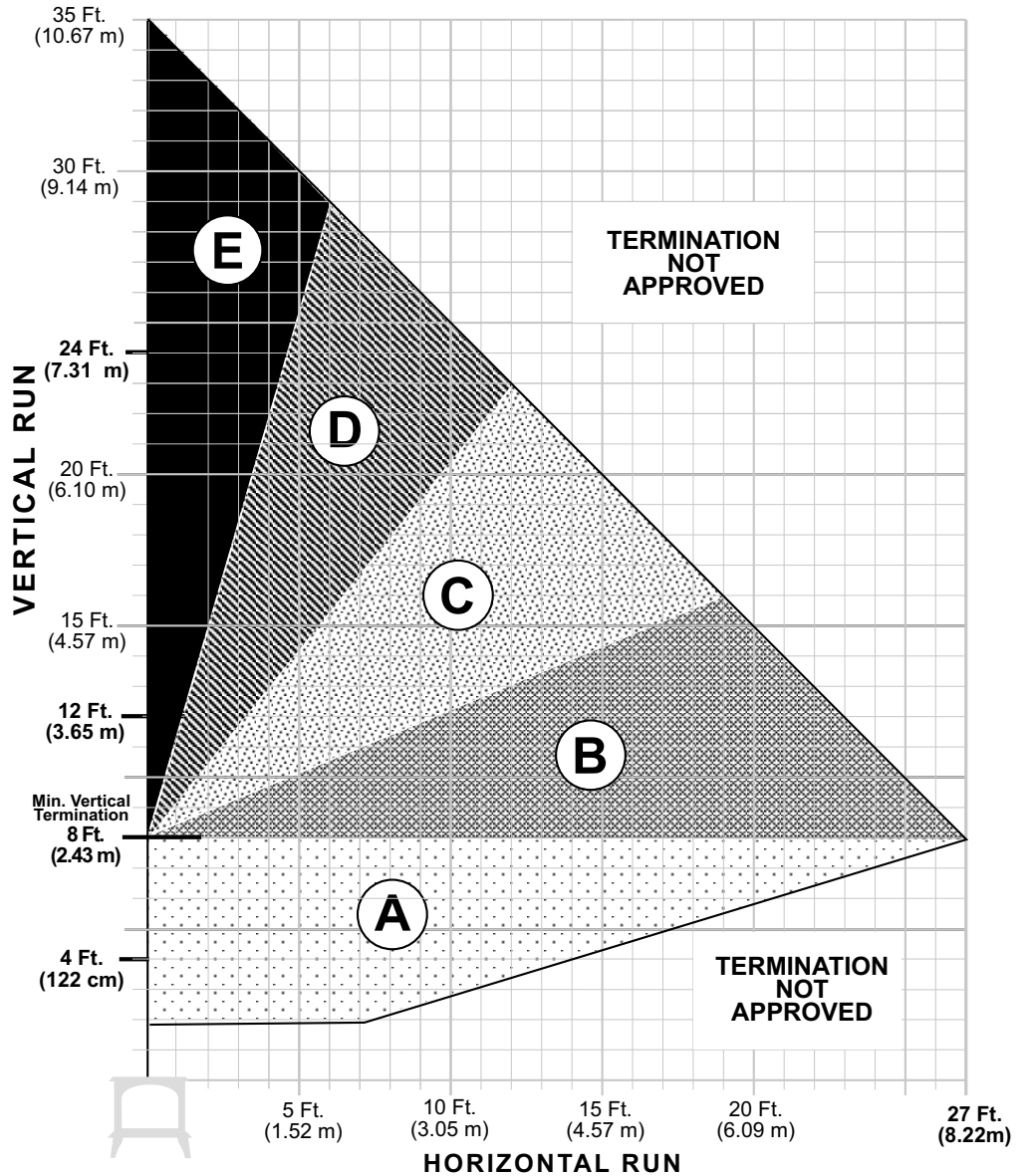
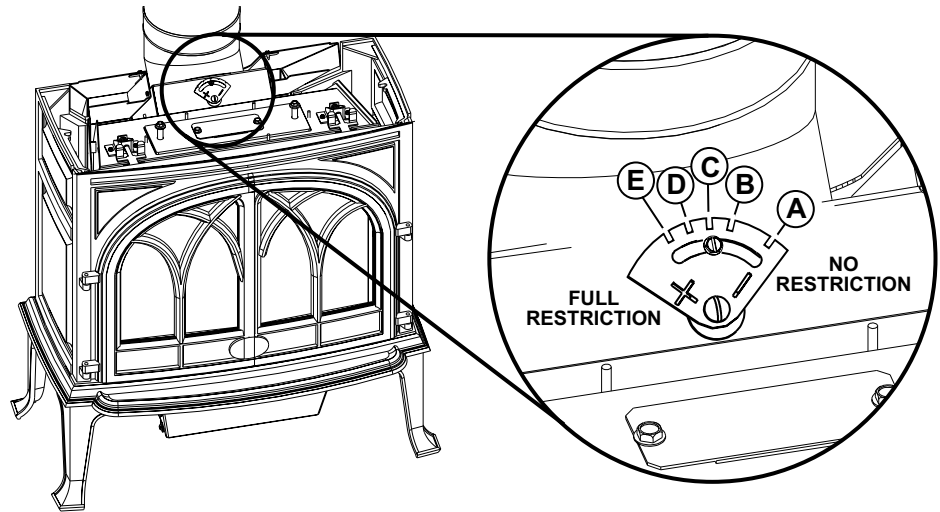

Figure 9. Vent Termination Matrix - NG / LP

Vertical Vent Termination

The Jøtul GF 400 DV IPI can be vertically vented through a ceiling or to a roof termination with the following guidelines:

- The termination should fall within the shaded areas of the grids depicted in the Vent Matrix on page 9.
- **Total run** should not exceed **35 ft.** (10.66 m).
- **Minimum Vertical run must be at least 8 ft.** (2.43 m).
- **Maximum Colinear Horizontal run is 2 ft.** (61 cm).
- **Vent Terminus Clearance:** In no case shall any discharge opening on the cap be less than 18 in. (610 mm) horizontally from the roof surface.
- Steep roofs, nearby trees, and predominantly windy conditions can contribute to poor draft and/or promote down-draft. Increasing the height of the vent may alleviate these conditions.
- Use Wall Straps to support an offset pipe run at intervals of three feet to avoid excessive stress on the offsets.
- **Elbows:** Four 45°, or two 90° elbows may be used. Do not include the 45° elbow attached to the stove. Whenever possible use 45° elbows instead of 90° elbows as they are less restrictive to exhaust gas and intake air flow.
- A firestop is required at every floor. The floor opening should be framed to 10" X 10" inside dimension.
- Any venting that is exposed in living space above the first floor must be enclosed. Always maintain the required 1" clearance from all sides of the vertical vent system. Insulation in attic space must be retained by an insulation barrier.

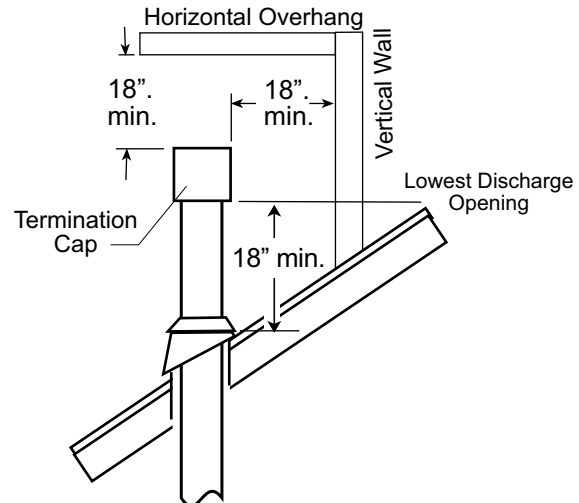

Figure 10. Vertical vent termination height above roof.

Co-linear Vent Installation

The GF 400 DV IPI may be vented through a masonry or Class A prefabricated chimney using a Co-linear Flexible Vent system approved for use with a solid-fuel burning fireplace. When installed in the manner described below, this system can improve the performance of the appliance in cold climate situations, as well as simplify the vent installation. See figs. 11 and 13.

Consult with the local code authority having jurisdiction before proceeding with this type of installation.

Refer to the vent manufacturer's instructions for specific installation requirements.

These installation requirements must be followed:

1. Use the guidelines for vertical termination on page 9.
2. Prior to the installation the chimney flue must be thoroughly cleaned and inspected by a qualified chimney service person.
3. In a masonry chimney, a fireclay liner must be present the entire length of the chimney.
4. Prefabricated chimneys must be UL 103 or ULC S-629 listed and have a minimum INSIDE diameter of 6 inches, (150 mm).
5. No appliance can be installed into a chimney flue serving any other appliance of any kind.
6. THE AIR INTAKE FLEX PIPE MUST EXTEND 6 FEET BEYOND THE DAMPER AREA OF THE FIREPLACE.
7. If the intake flex duct does not extend the full length of the chimney and connect to both the unit and the termination cap, A METAL BLOCK OFF PLATE MUST BE CONSTRUCTED AND INSTALLED ABOVE THE UNIT PRIOR TO THE END OF THE INTAKE FLEX AND MUST COMPLETELY SEAL THE CHIMNEY FLUE FROM THE ROOM.

If there is enough vent length and room in the flue, adding a return loop in the air intake run will help prevent draft reversals that can cause cold start problems.

WARNING: FAILURE TO POSITION THE PARTS AND STOVE IN ACCORDANCE WITH THESE DIAGRAMS OR FAILURE TO USE ONLY PARTS SPECIFICALLY APPROVED FOR USE WITH THIS APPLIANCE MAY RESULT IN PROPERTY DAMAGE OR PERSONAL INJURY. BE SURE TO MAINTAIN THE CLEARANCES TO COMBUSTIBLES SPECIFIED IN THIS MANUAL AND IN THE INSTRUCTIONS PROVIDED WITH EACH VENT COMPONENT.

NOTE: THIS VENT CONFIGURATION MAY REQUIRE THE APPLIANCE BE OPERATED IN CPI MODE TO ASSURE ADEQUATE DRAFT AND PROPER PERFORMANCE.

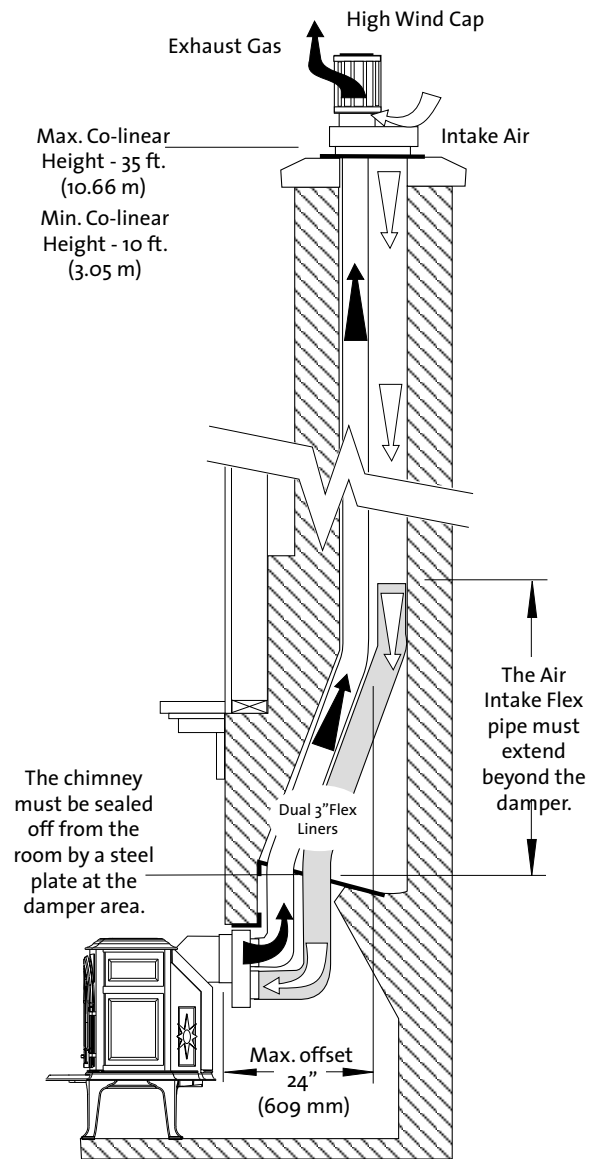

Figure 11. Co-linear Adaptor installed through a masonry chimney. Components shown may differ somewhat from manufacturer to manufacturer.

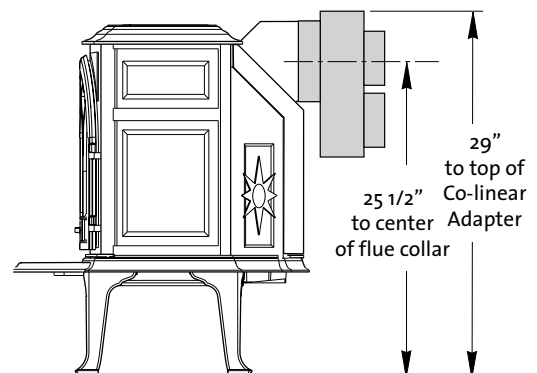

Figure 12. Simpson Dura-Vent #923GCL Co-linear Adaptor is shown - other manufacturer's components may differ. Subtract 2 1/4" for Short Legs.

Masonry or Prefabricated Chimney Conversion

IMPORTANT NOTICE

IN THE U.S., THE USE OF AN EXISTING CHIMNEY AS AN AIR INTAKE IS NOT COVERED UNDER THE ANSI Z21.88-1999-CSA 2.33-M99 TEST METHODS AND RESULTING ITS/WHI PRODUCT CERTIFICATION. THE CODE AUTHORITY HAVING JURISDICTION MUST BE CONSULTED PRIOR TO PROCEEDING WITH THIS INSTALLATION METHOD.

THIS INSTALLATION IS NOT APPROVED IN CANADA.

The GF 400 DV IPI is approved for use with components of Simpson DuraVent Chimney Kit 46DVA-KMC and 46DVA-KCT in a masonry chimney or a Kits 46DVA-KCA, 46DVA-KCB, and 46DVA-KCC for prefabricated solid fuel listed chimneys.

These installation requirements must be followed:

1. Use the guidelines for vertical termination shown on page 9.
2. In masonry chimney, a fireclay liner or listed steel liner, must be present the entire length of the chimney.
3. Chimney height should not exceed 35 ft. (10.67 m).
4. The liner must have an inside dimension of 6" round or greater.
5. Prefabricated chimneys must be UL 103 or ULC S-629 listed and have a minimum INSIDE diameter of 6 inches, (150 mm). Prefabricated chimneys must be listed for the specific Simpson Dura-Vent Chimney Conversion Kits noted above.

Horizontal Termination

- Any horizontal termination must fall within the shaded portion of the vent window matrix shown in fig. 9. For Snorkel Terminations, see page 13.
- Any horizontal termination except a snorkel termination, must include:
 - 1) Minimum rise of 24 in.
 - 2) Minimum horizontal run of 12 in.
 - 3) Vertical run no more than 35 ft.
 - 4) Horizontal run no more than 27 ft.
 - 5) No more than four 45° or two 90° Elbows. The run must be reduced by 5 feet for each additional elbow.
- The horizontal termination cap must maintain a 3" clearance to any overhead combustible projections 2 1/2" or less. It must also maintain 12" clearance from projections exceeding 2 1/2". See fig. 19.
- Wall Cut-out Opening: A minimum 10" X 10" (250 mm x 250 mm) square hole is required for proper pipe clearances through a combustible wall.

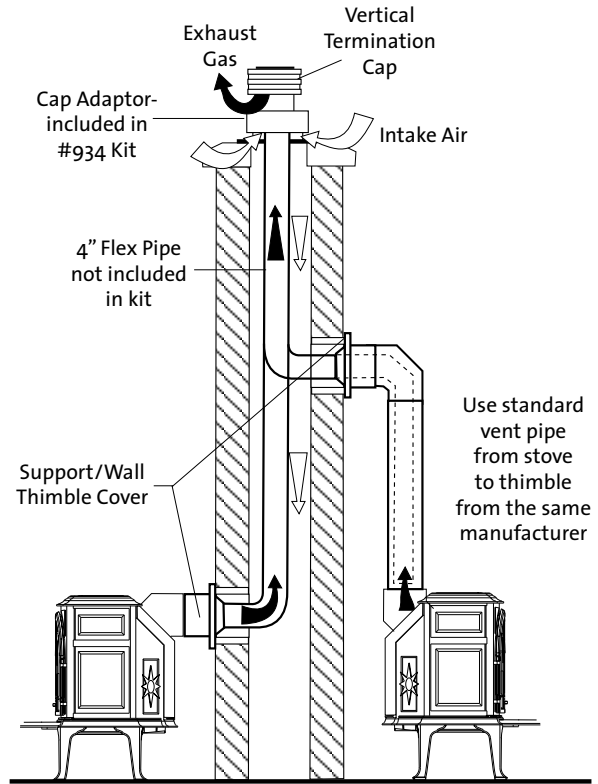

Figure 13. Vent System through a masonry chimney using a chimney conversion kit. May also be used in listed prefabricated chimneys. Drawing is for illustrative purposes only - DO NOT VENT TWO APPLIANCES INTO A SINGLE CHIMNEY.

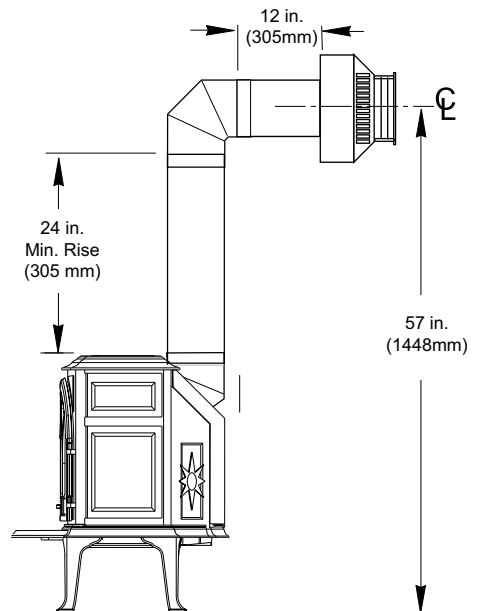

Figure 14. Minimum vent required for horizontal termination.

DO NOT FILL AIR SPACE WITH ANY TYPE OF INSULATION.

- Any horizontal run of vent must be level or have a 1/4 in. rise for every foot of run toward the termination cap. NEVER ALLOW THE VENTING TO RUN DOWNWARD FROM STOVE TO TERMINATION; DOWNWARD VENT RUNS TRAP HEAT AND CAUSE HIGH TEMPERATURES TO DEVELOP WITHIN THE VENT THAT COULD START A FIRE.
- Install a Vinyl Siding Standoff (Simpson Dura-Vent #950) between the vent termination and an exterior wall covered by vinyl siding material to prevent potential heat damage to the siding.
- Do not recess the termination cap into a wall or siding.

Snorkel Terminations

Air Deflector Plate Installation

Four air deflectors are included with the stove for use in snorkel terminations. For identification, see parts #1, 2, 3 and 22, Fig. 70, page 35. Parts 1 and 22 are shipped flat in the Miscellaneous Hardware kit.

The large Snorkel Plate (#1) should be installed on all snorkel-terminated stoves.

The two smaller Burner Air Deflectors (#2, 3) and Pilot Tray (#22) should ONLY be used on stoves using Natural Gas.

1. Lift the Burner Skirt up and out of the stove.
2. **NATURAL GAS ONLY:** Remove the Burner with removal of four sheet metal screws that attach the burner supports to the firebox floor.

Bend up the two, small, pre-installed Burner Air Deflector plates to a 90° angle as shown in fig. 17.

Bend up the Pilot Tray and attach it to the floor using the rear screw on the pilot base. See also Appendix, fig. 73, page 37.

3. **LP and NG:** Attach the Snorkel Plate (shipped in the Miscellaneous Hardware bag) to the rear of the burner skirt using the pre-installed sheet metal screws. See #1, fig. 70, page 35. Bend the plate up 90° at the perfs.

■ **14" Snorkel:** Only approved for maximum 12" horizontal termination with no elbow.

■ **36" Snorkel:** The maximum horizontal run may be no more than 6 ft. (182 cm.)

One 45° Elbow may be used for a corner installation as shown in fig. 16.

■ **Exhaust Restriction:** Under normal circumstances, no exhaust restriction is recommended. Keep the factory setting (Position A - fully open).

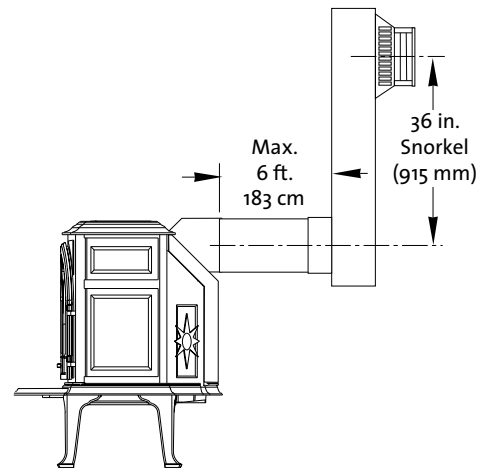

Figure 15. Maximum Horizontal and Vertical Run with 36" Snorkel Termination.

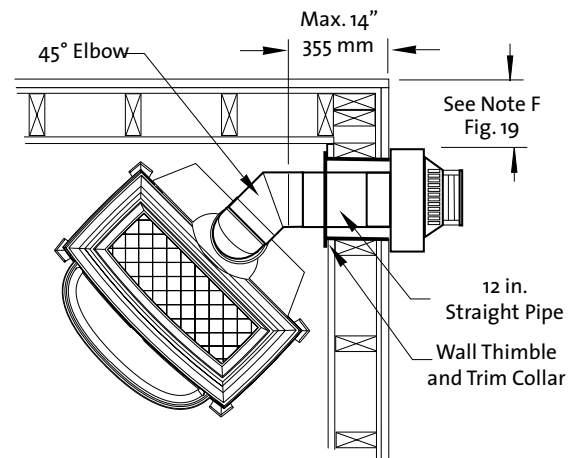

Figure 16. Corner Installation with 36" Snorkel Termination.

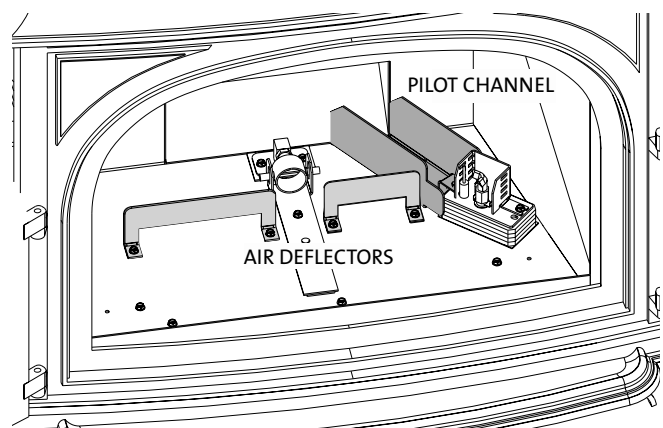

Figure 17. **NG SNORKEL TERMINATION ONLY** - Bend up burner Air Deflectors and perpendicular to the firebox floor. Install Pilot Tray as shown

Horizontal Termination Clearance

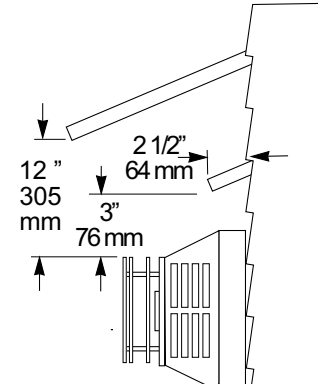
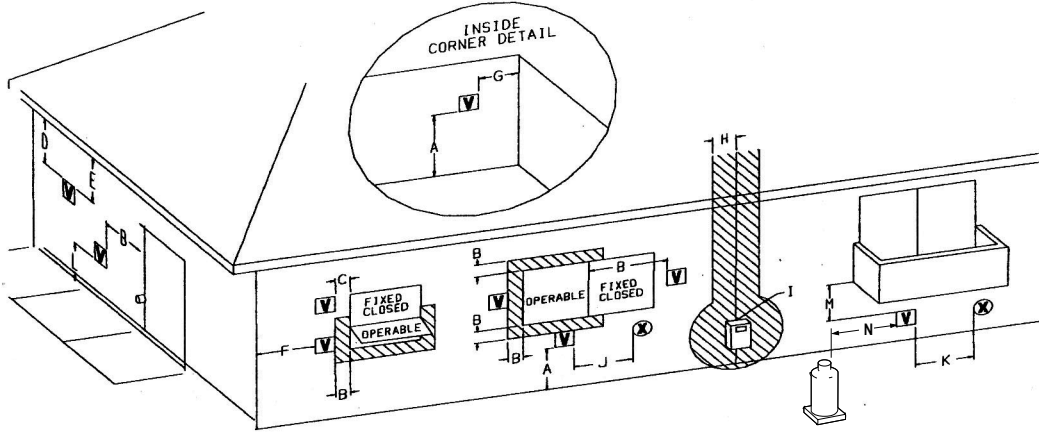

Figure 19. Termination Clearance to overhangs.

Figure 18. Vent Terminal Clearances, Canada and United States

		Canadian Installations ¹	U.S. Installations ²
A	Clearance above grade, veranda, porch, deck, or balcony	12 in. (30 cm)	12 in. (30 cm)
B	Clearance to window or door that may be opened	12 in. (30 cm)	9 in. (23 cm) We recommend 12 in. to prevent condensation on a window.
C	Clearance to permanently closed window	12 in. (30 cm)	9 in. (23 cm) We recommend 12 in. to prevent condensation on a window.
D	Vertical clearance to ventilated soffit located above the terminal within a horizontal distance of 2 ft (60 cm) from the center line of the terminal	18 in. (46 cm)	18 in. (46 cm)
E	Clearance to unventilated soffit	12 in. (46 cm)	12 in. (46 cm)
F	Clearance to outside corner	12 in. (46 cm)	9 in. (23 cm) We strongly recommend 12 in. particularly where strong winds prevail.
G	Clearance to inside corner	12 in. (46 cm)	9 in. (23 cm) We strongly recommend 12 in. particularly where strong winds prevail.
H	Clearance to each side of center line extended above a gas meter or regulator	3 ft. (91 cm) within a height 15 ft. above the meter/regulator assembly	*
I	Clearance to service regulator vent outlet	3 ft. (91 cm)	*
J	Clearance to nonmechanical air supply inlet to building or the combustion air inlet to any other appliance	12 in. (30 cm)	9 in. (23 cm)
K	Clearance to a mechanical air supply inlet	6 ft. (1.83 m)	3 ft. (91 cm) above if within 10 ft. (3 m) horizontally
L	Clearance above paved sidewalk or paved driveway located on public property	7 ft. (2.13 m) ³	*
M	Clearance under veranda, porch, deck, or balcony	12 in. (30 cm) ⁴	12 in. (30 cm) ⁴
N	Clearance to propane tank relief valve and filler connection	5 ft. (1.52 m) ⁵ / 10 ft. (3.05 m) ⁶	5 ft. (1.52 m) ⁵ / 10 ft. (3.05 m) ⁶

1) In accordance with the current CSA B149.1, Natural Gas and Propane Installation Code.

2) In accordance with ANSI Z223.1/MNPA 54, National Fuel Gas Code

* For clearances not specified in ANSI Z223.1/NFPA or CSA B149.1, the clearance will be in accordance with local installation codes and the requirements of the gas supplier.

3) A vent shall not terminate directly above a sidewalk or driveway which is located between two single family dwellings and serves both dwellings.

4) Permitted only if veranda, porch, deck, or balcony is fully open on a minimum of two sides beneath the floor.

5) Minimum clearance to tanks not filled on site.

6) Minimum clearance to tanks filled on site from bulk truck.

Mobile Home Installation

The GF 400 DV IPI can be installed for use in a mobile home in the U.S. and Canada provided:

1. The stove is secured to the floor of the mobile home. Use Jøtul Floor Bracket Kit #750304.
2. Provision must be made to secure an electrical ground between the stove and the mobile home chassis.
3. The stove is installed in accordance with Title 24 CFR, Part 3280- Manufactured Home Construction and Safety Standard, in the U.S. In Canada, comply with CSA Z240.4, Gas Equipped Recreational Vehicles and Mobile Housing.
4. Always contact your local officials about installation restrictions and requirements in your area.

THIS APPLIANCE MAY BE INSTALLED AS AN OEM INSTALLATION IN A MANUFACTURED (MOBILE) HOME AND MUST BE INSTALLED IN ACCORDANCE WITH THE MANUFACTURER'S INSTRUCTIONS AND THE MANUFACTURED HOME CONSTRUCTION AND SAFETY STANDARD, TITLE 24 CFR, PART 3280. THIS APPLIANCE IS ONLY FOR USE WITH THE TYPE OF GAS THAT IS INDICATED ON THE STOVE'S RATING PLATE. A GAS CONVERSION KIT IS PROVIDED WITH THE GF 400 DV IPI GAS STOVE.

THIS APPLIANCE MAY BE INSTALLED IN AN AFTERMARKET PERMANENTLY LOCATED, MANUFACTURED (MOBILE) HOME, WHERE NOT PROHIBITED BY LOCAL CODES.

CET APPAREIL PEUT ETRE INSTALLE DANS UN MAISON PREFABRIQUEE (MOBILE) DEJA INSTALLEE A DEMEURE SI LES REGLEMENTS LOCAUX LE PERMETTENT. CET APPAREIL DOIT ETRE UTILISE UNIQUEMENT AVEC LES TYPES DE GAS INDIQUES SUR LA PLAQUE SIGNALETIQUE. NE PAS L'UTILISER AVEC D'AUTRES GAS SAUF SI UN KIT DE CONVERSION CERTIFIE EST INSTALLE.

Fuel Conversion

The GF 400 DV IPI gas stove is shipped from the factory equipped to burn NATURAL GAS only. If PROPANE gas is to be used as fuel, the appliance must first be converted for using Propane Conversion Kit 157611 included with the stove. Use NG Conversion Kit 157612 to change back for use with natural gas.

WARNING:

THE CONVERSION KIT IS TO BE INSTALLED BY AN AUTHORIZED SERVICE TECHNICIAN IN ACCORDANCE WITH THE MANUFACTURER'S INSTRUCTION AND ALL CODES AND REQUIREMENTS OF THE AUTHORITY HAVING JURISDICTION. FAILURE TO FOLLOW THESE INSTRUCTIONS COULD RESULT IN SERIOUS INJURY OR PROPERTY DAMAGE. THE QUALIFIED AGENCY PERFORMING THIS WORK ASSUMES RESPONSIBILITY FOR THIS CONVERSION.

IN CANADA:

THE CONVERSION SHALL BE CARRIED OUT IN ACCORDANCE WITH THE REQUIREMENTS OF THE PROVINCIAL AUTHORITIES HAVING JURISDICTION AND IN ACCORDANCE WITH THE REQUIREMENTS OF THE CAN1-B149.1 AND .2 INSTALLATION CODE.

Tools required:

- 1/2" open ended wrench or deep-well socket, Torx T20 or slotted screwdriver, 7/16" open-end wrench.

Conversion Kit Contents:

- Air Shutter Stop Screw - LP kit only
- 1, regulator tower labeled for either LP or NG
- 2, regulator tower screws
- 1, burner orifice (#52 for LP, #36 for NG)
- Label A - to be completed and applied to the back of the stove
- Label B - apply to the stove Rating Plate
- Small valve label - apply to valve body

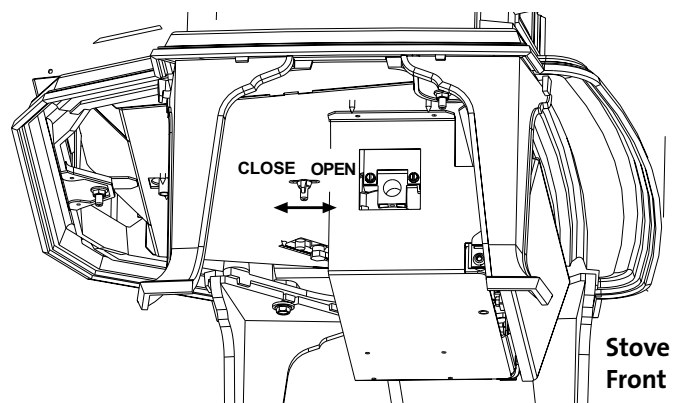

Figure 20. Loosen and adjust the air shutter.

Fuel Conversion Procedure

1. Turn off gas supply to stove.
2. Remove the stove Top Plate.
3. **Disengage the two Glass Frame Latches** and lift the glass panel frame up and out of the stove.
4. If installed, remove the Embers and Log Set using care not to damage the fragile log parts.
5. **Lift out the Burner Skirt.**
6. Reach under the stove and loosen the Air Shutter wing-nut. Push the shutter stem back to ease burner removal. See fig. 20.
7. **Lift out the Burner Plate** with removal of four screws from the firebox floor. See fig. 21.
8. **Change the Burner Injector.** See fig. 22. Using a 1/2" open end wrench or deep-well socket remove the burner orifice from its elbow housing and replace with the appropriate orifice supplied in the kit.
9. **LP CONVERSION ONLY:**
 - A) **Install the stop screw into the air shutter plate.** See fig. 22.
10. **CHANGE THE INTEGRATED DUAL-FUEL PILOT ORIFICE:** Use the 7/16" wrench to just loosen the pilot head enough to push in the adjustment slide. See fig. 23.
 - LP : push tab to the left (red dot exposed on slide).
 - NG: push tab to the right.
11. **Replace the Burner Plate.** Engage the burner tube with the Air Shutter assembly. Be sure the burner is level and secure the support brackets to the floor with the screws previously removed.
12. **Replace the Valve Regulator.** Using a Torx T-20 screwdriver, remove the two screws from the front of the regulator. Remove the regulator components and replace with the one from the conversion kit. See fig. 24.
13. **Install the identification labels** to the stove so that they can be seen by any person who may be servicing the stove.
 - Label A: apply to back of stove
 - Label B: apply to the rating plate attached to the back of the stove.
 - Small Conversion Label: apply to valve.
14. Reassemble the stove, apply gas to the system and check for leaks using a soapy water solution or gas detector. See Leak Test caution on next page.
NEVER USE AN OPEN FLAME TO CHECK FOR GAS LEAKS.

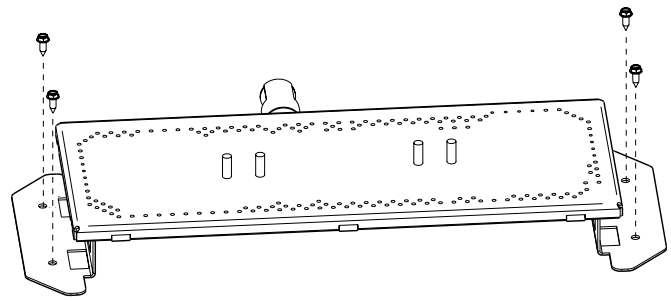

Figure 21. Remove four sheet metal screws to lift burner out of the firebox.

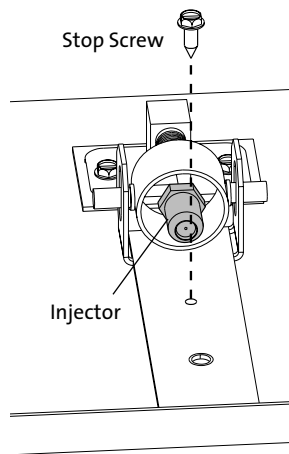

Figure 22. Burner injector and LP stop screw.

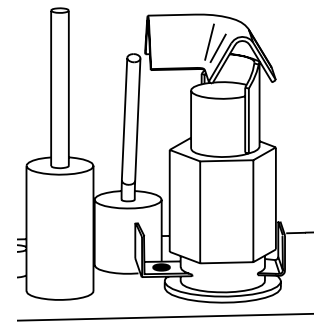

Figure 23. Integrated dual-fuel pilot orifice - LP position shown.

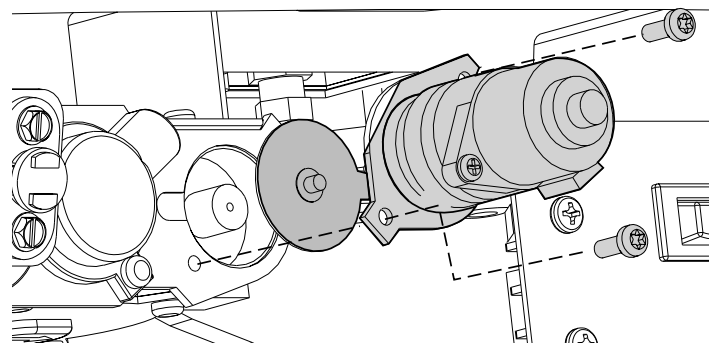

Figure 24. Manual Regulator replacement.

Fuel Conversion, cont'd.

15. Correct gas pressure is essential for efficient and safe operation of this appliance. Use a manometer to check pressures as specified in the Gas Pressure section of this manual (page 18).
16. **Adjust the Air Shutter.** You will need to position the shutter to provide a gas/air mixture that will achieve the best flame picture with your particular installation. Start with the shutter stem at the half-way position in the slot in the bottom of the stove. See fig. 20. Pushing the stem back will restrict air, while pushing it forward will open the shutter and increase air. With some experimentation, you will find the shutter position that works best for your installation.

The factory setting for natural gas is open 1/16".

The factory setting for propane is open 1/4".

ALWAYS REFER TO THE LIGHTING INSTRUCTIONS ON THE INSIDE BACK COVER OF THIS MANUAL WHEN LIGHTING YOUR STOVE.

Gas Supply Connection

NOTE: If appropriate, install the optional forced air blower before connecting the gas line, to prevent clearance interference between the two.

The gas supply line connection is made to the left side of the valve. The gas supply line should be 3/8" npt with a 1/2" diameter supply, or the appropriate size to provide sufficient gas pressure to the valve regardless of the input setting.

The use of Flexible Gas Appliance Connectors is acceptable in many areas in the U.S. However, Canadian methods vary depending on local code.

ALL INSTALLATIONS MUST COMPLY WITH LOCAL CODE OR IN THE ABSENCE OF LOCAL CODE, MUST COMPLY WITH THE MOST RECENT EDITION OF THE NATIONAL FUEL GAS CODE ANSI Z223.1/NFPA 54 OR CAN-B149.

All codes require a gas shut-off valve (gas cock) and union, to be installed in the supply line, and in the same room as the appliance. This allows for the disconnection of the stove for servicing and maintenance. See fig. 25.

A T-HANDLE GAS COCK IS REQUIRED IN MASSACHUSETTS TO COMPLY WITH CODE 248CMR.

Secure all joints tightly using appropriate tools and sealing compounds. If Propane is used, be sure to use sealant compounds that are propane resistant. Turn on gas supply and test for gas leaks using a soapy water solution, or digital gas detector. Never use an open flame to check for leaks.

LEAK TEST



WARNING!

USE A SMALL BRUSH TO APPLY LEAK SOLUTIONS. AVOID CONTACT WITH ELECTRICAL CONNECTIONS. USE OF A SPRAY BOTTLE MAY DAMAGE SENSITIVE ELECTRONIC COMPONENTS. NEVER USE AN OPEN FLAME TO CHECK FOR GAS LEAKS.

1. Mix a 50-50 solution of water and dish soap.
2. Light appliance; see lighting instructions on the inside back cover of this manual or on the stove's rating plate.
3. Brush all joints and connections with the soapy water solution. If bubbles appear at any connection or seam or a gas odor is detected, immediately turn gas control knob to the OFF position.
4. Tighten or reconnect the leaking joint and retest.

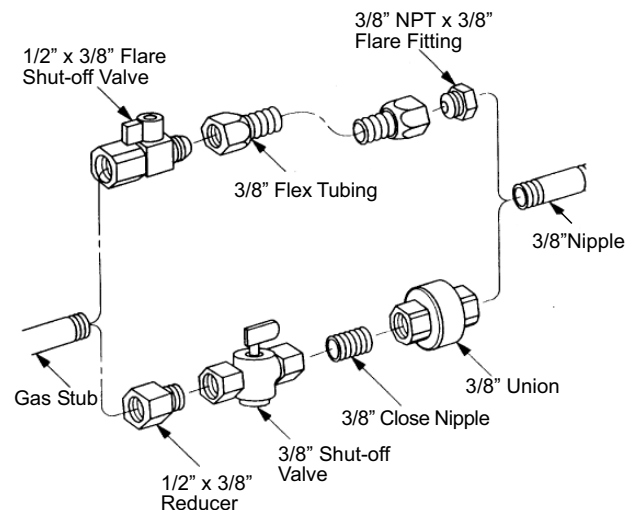

Figure 25. Supply valve connection fittings.

Gas Pressure

Correct gas pressure is essential for efficient and safe operation of the GF 400 DV IPI gas stove. It is important that the correct pressure is established at the time of the installation. Proper gas pressure provides a consistent flow of gas to the appliance and is instrumental in checking for gas leaks.

Pressure Test: Attach a manometer to the appropriate test point on the valve. See fig. 26. The gauge connections are located on the front of the valve. Connections are identified by:

E - for Inlet or Supply Pressure (the amount of gas coming to the valve.)

A - for Manifold Pressure (the amount of gas that is coming out of the valve to the burner.)

ALWAYS TEST PRESSURES WITH VALVE CONTROL KNOB SET ON HIGH.

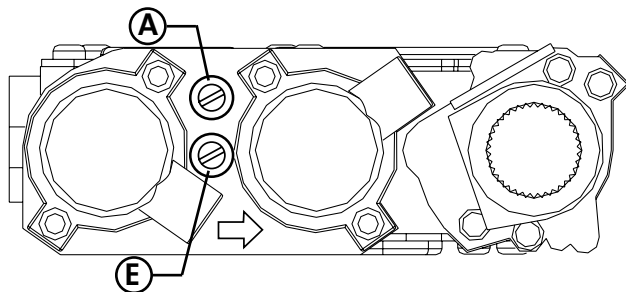

Figure 26. Pressure test points.

INLET GAS PRESSURES (inches water column)		
	MIN	MAX
NATURAL GAS	5.0	7.0
PROPANE	12.0	14.9

The appliance and its appliance main gas valve must be disconnected from the gas supply piping system during any pressure testing on that system at test pressures in excess of 1/2 psig (3.5 kPa).

The appliance must be isolated from the gas supply line by closing its individual manual gas shut-off valve (gas cock) during any pressure testing of the gas supply piping system that is equal to or less than 1/2 psig (3.5 kPa).

MANIFOLD PRESSURES (inches water column)		
	MIN	MAX
NATURAL GAS	1.1	3.8
PROPANE	2.9	11.0

High Altitude Adjustment

LP Kit #157613

NG Kit #157614

The decreased atmospheric pressure of higher altitudes affects heat value of gaseous fuels. Most gas suppliers derate the gas intended for use at elevations above 2000 feet. Check with your gas supplier before performing derate adjustment to the burner.

This appliance may be adjusted for altitude over 2000 ft. (610 - 1371 m) for propane or natural gas. If the gas supplier does not derate fuels, install High Altitude Adjustment Kit 157613 for propane gas or Kit 157614 for natural gas.

U.S & Canada per ANSI Z21.88-2009 • CSA 2.33-2009, CAN/CGA 2.17

See data plate for additional information. For high altitude installations consult the local gas distributor or the authority having jurisdiction for proper rating methods. If the installer must convert the unit to adjust for varying altitudes, the information label must be filled out and applied to the appliance at the time of the conversion.

Cet appareil est équipé pour gaz naturel des altitudes comprises entre 0 et 4500 pieds (0-1372 m) seulement.

Derating Procedure

- Follow Steps 1-8 of the Fuel Conversion procedure on page 16 to change the burner injector. Use the injector supplied with the adjustment kit. Detailed instructions are also included in the kit.
- Conduct gas leak and gas pressure tests as detailed on this page.
- Conduct system check and flame picture adjustments as specified on pages 23 and 24.

INSTALLER: Fill out the appropriate information and apply the high altitude conversion label provided to the rating plate on the appliance. See fig. 27.

This appliance has been converted for use at an altitude of _____.	
Orifice Size: _____	Manifold Press. _____
Input Btu/Hr. _____	Fuel Type _____
Date: ___/___/___	Converted by: _____
Cet appareil a été converti au _____ Injecteur _____	
Pression à la tubulure d'alimentation _____	
Débit calorifique _____	

Figure 27. High Altitude Conversion Label.

Log Set Installation

Brick Kit Note: Install the optional Reversible Panel Kit 157603 before installing the log set. See page 19 or the instructions provided with that kit.

The GF 400 DV IPI log set must be installed before operating the burner. The log set includes six log pieces, packaged inside the firebox. A quantity of ember stones is with the log set. Place the parts inside the firebox as illustrated in figs. 30-33.

WEAR GLOVES AND HANDLE THE LOG PARTS CAREFULLY.

#157602 Log Set Identification

- | | | | |
|----|---------------------|----|----------------------|
| #1 | Rear, 225031 | #5 | Right Middle, 225037 |
| #2 | Left Side, 225032 | #6 | Left Upper, 225034 |
| #3 | Right Side, 225033 | #7 | Right Upper, 225035 |
| #4 | Left Middle, 225036 | | |

IMPORTANT

The ember stones, found in the hardware bag, realistically simulate glowing coals when the burner is operating. These should be spread evenly over the burner plate and around the logs.

TO INSURE PROPER BURNER FUNCTION, DO NOT OBSTRUCT THE PILOT ASSEMBLY AND BURNER SKIRT OPENINGS WITH EMBER STONES. KEEP EMBERS AWAY FROM THE PILOT CARRY-OVER PORTS.

You do not need to use all of the ember stones. With some experimentation, you will find the arrangement and quantity of embers that works best with your stove. Depending upon the characteristics of your installation, it is possible that too many ember stones can promote sooting on the logs. Adjust the quantity of ember stones as appropriate to maintain the best overall flame picture and burner performance.

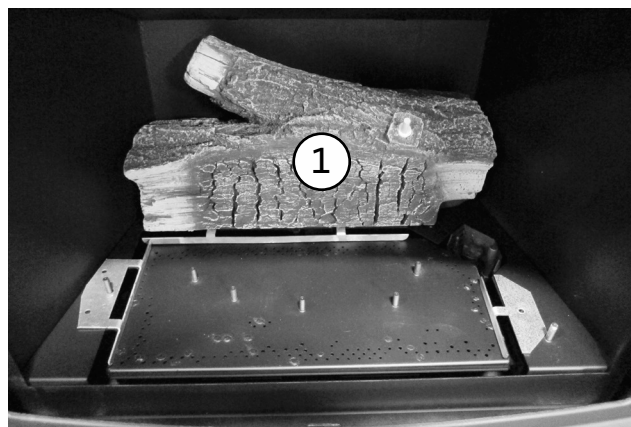

Figure 30. Locate the Rear Log over the two pins on the back shelf of the burner skirt.

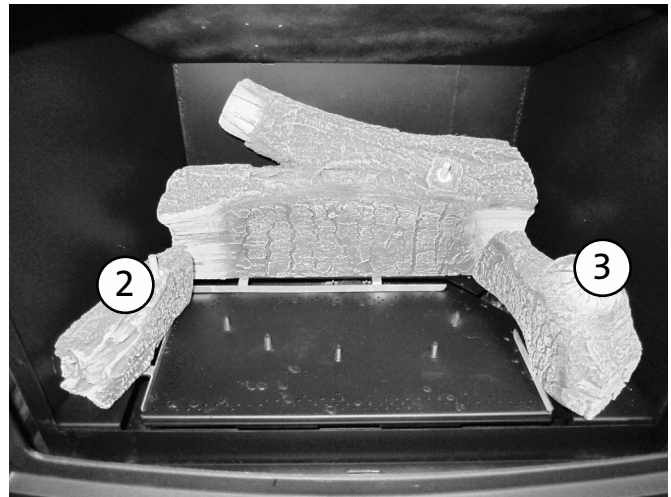

Figure 31. Place the Left and Right Front Logs on the pins in the center of the burner plate.

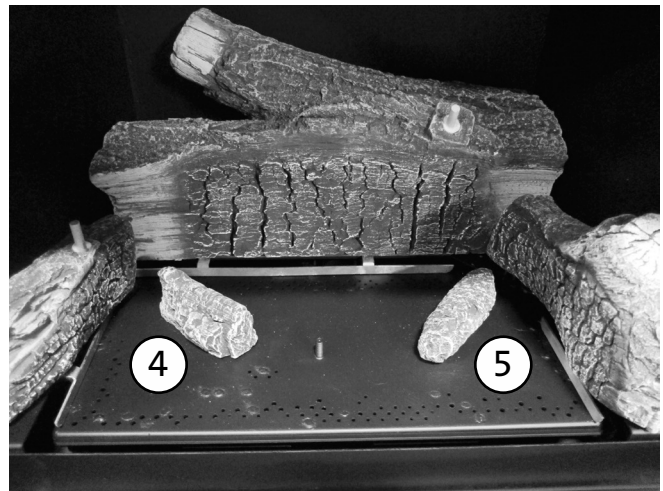

Figure 32. Position the Left and Right Middle logs on the burner pins.

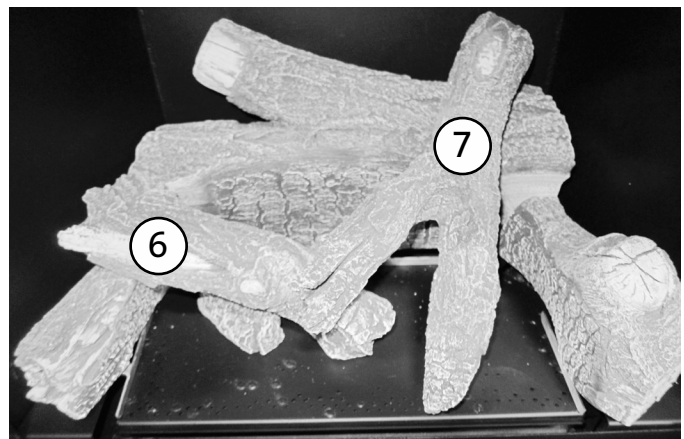

Figure 33. Position the Left and Right Upper logs on the appropriate burner pins.



Figure 34. Spread ember stones evenly across the burner plate, avoiding the perimeter edges.

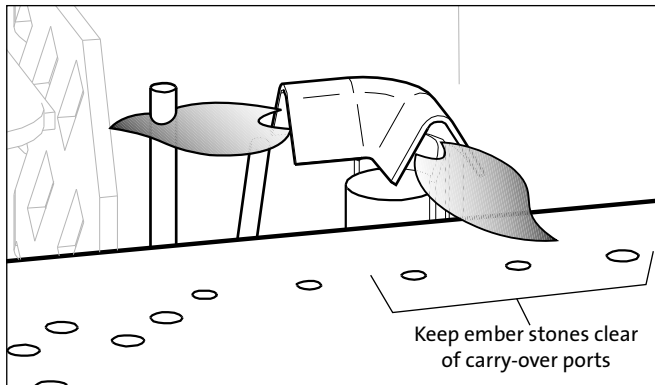

Figure 35. Proper pilot flame appearance relative to burner carry-over porting.

Optional Wall Thermostat

Use only a 750 millivolt DC two-wire circuit wall thermostat with this appliance. The thermostat should be placed in the same room as the heater, typically 5 feet off the floor. Avoid drafty areas or any area that may affect the accuracy of the thermostat.

The thermostat should be connected to the GF 400 DV IPI using a minimum of 16 gauge wire with a maximum length of 25 feet of wire.

Connect the two thermostat wire leads to the terminals on the block located to the left of the valve. Do not overtighten the connections. **IT IS NOT NECESSARY TO DISCONNECT ANY OTHER WIRES.** See Fig. 36.

For thermostatic operation, set the On/Off/T-Stat switch to the T-stat position. Set the pilot mode to either IPI or CPI.

At the thermostat, the two wires should be connected to the two connection screws on the thermostat base plate per the manufacturer's instructions.

CAUTION:

LABEL ALL WIRES PRIOR TO DISCONNECTION WHEN SERVICING THE CONTROLS. WIRING ERRORS CAN CAUSE IMPROPER OR DANGEROUS OPERATION. ALWAYS VERIFY PROPER OPERATION AFTER SERVICING THE APPLIANCE.

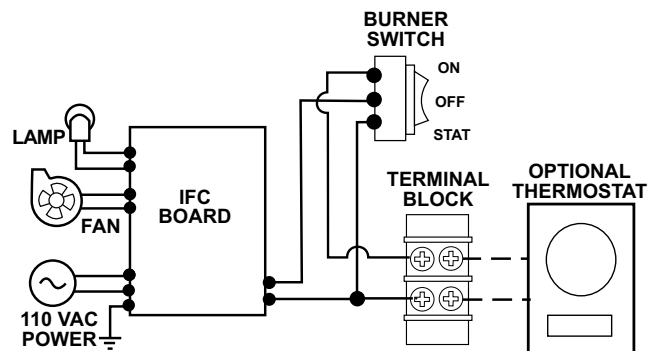

Figure 36. Accessory wiring diagram.

System Check

1. **PURGING THE GAS LINE:** When lighting the appliance for the first time, it will take a few moments to clear the gas line of air. Once this purge is complete, the appliance will operate as described in the lighting instructions. From a cold start, it may be helpful to let the pilot light burn in CPI mode for 10 - 15 minutes to establish positive draft, before turning the burner on. See the procedure on the inside back cover of this manual. Subsequent burner starts will not require purging the gas line unless the supply line is shut off.
2. **PILOT FLAME:** You can monitor the pilot flame located under the Rear Log. See fig. 35, page 21. The pilot flame should be steady - not lifting or floating. The flame should be blue in color around the pilot hood, with traces of yellow toward the outer edges.

The pilot flame should engulf the top 1/8" of the flame sensor. The pilot flame should project front pilot hood port toward the burner plate carry-over ports. Adjust the pilot flame using the adjustment screw to the left of the valve regulator.

3. **MANUAL BURNER ADJUSTMENT:** This stove is equipped with a variable gas control valve that allows manual adjustment of the flame height and heat output. To adjust the flame intensity, rotate the regulator knob, Fig. 37. Flame height will adjust approximately 50% between the LOW and HIGH settings.

NO SMOKE OR SOOT SHOULD BE PRESENT. CHECK LOG PLACEMENT IF ANY SOOT OR SMOKE IS PRESENT. IF SOOT OR SMOKE PERSISTS, THE AIR SHUTTER MAY NEED TO BE ADJUSTED.

See Flame Appearance / Air Shutter section of this manual for proper air shutter settings and adjustments. Note: the more offsets there are in the vent system, the greater the need for an air shutter adjustment. See fig. 39, page 23.

WARNING:
AIR SHUTTER ADJUSTMENTS SHOULD ONLY BE PERFORMED BY A QUALIFIED, PROFESSIONAL SERVICE TECHNICIAN.

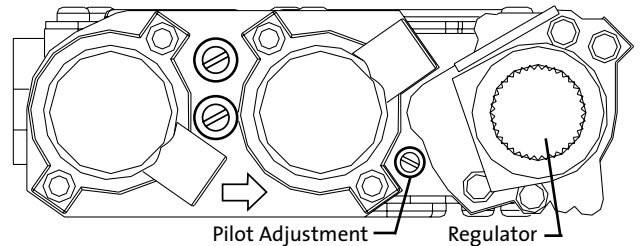

Figure 37. Manual flame regulation.

Flame Appearance / Air Shutter Adjustment

The GF 400 DV IPI gas stove is shipped from the factory equipped to burn Natural gas. If the stove has been converted for use with propane, the Air Shutter adjustment range should be limited using the stop screw supplied with the conversion kit. For natural gas, the Air Shutter may be adjusted to provide the best flame picture for your specific installation.

Other installation related variables can also affect the flame picture.

Too large an air setting - the appliance will generate a flame that is blue and transparent, or an “anemic” flame.

Too small an air setting - the appliance will generate very long yellow flames resulting in soot. Sooting produces black deposits on the logs, on the inside walls of the appliance, and potentially on the exterior termination cap. Sooting is caused by incomplete combustion in the flames and lack of combustion air entering the air shutter opening.

To adjust the air shutter:

1. Reach under the stove and loosen the wingnut. See fig. 38. Slide the wing nut stud forward to open the air shutter and back to provide less air. Before making any adjustments, start at the factory shutter settings:
 - Natural Gas - open 1/16”
 - Propane - open 1/4”
2. Allow the stove to burn for 30 minutes on the HIGH setting, observing the flame continuously. If the flame appears weak, slow, or sooty, increase the air shutter opening in 1/16” increments until the desired flame picture is achieved.
3. Tighten the wingnut to secure the shutter at the desired setting.

WARNING: AIR SHUTTER ADJUSTMENTS SHOULD ONLY BE PERFORMED BY A QUALIFIED PROFESSIONAL SERVICE TECHNICIAN.

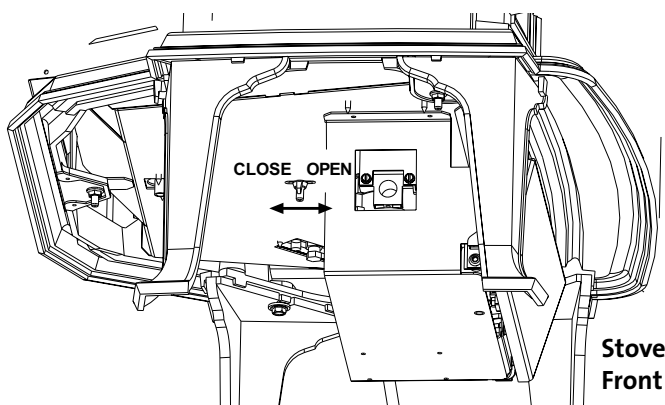

Figure 38.
Loosen the wingnut to adjust the air shutter.



Figure 39. Normal flame picture.

Initial Operation Notes

Check the build date on the shipping crate label. If it has been more than 6 months since the build date, be prepared to replace the IFC batteries located in the valve compartment.

1. For the first several hours of operation, it is common to detect some odor as the metal and manufacturing materials cure under heat. This condition is temporary and can be alleviated by allowing plenty of fresh air to circulate through the area.
2. Condensation may develop on the glass upon each lighting of the appliance. This “fog” will disappear as the glass heats.
3. **IMPORTANT: It will be necessary to clean the glass after the first few fires. A white powdery residue will be evident which results from the burner media curing. Use a non-abrasive household glass cleaner and warm water. IF THE GLASS IS NOT CLEANED, THIS RESIDUE CAN CAUSE THE GLASS TO BECOME PERMANENTLY ETCHED. DO NOT USE AMMONIA-BASED CLEANERS.**
4. Keep the control compartments and area under the appliance free of dust. Always keep the appliance area clear and free from combustible materials, gasoline and other flammable liquids.
5. This appliance can be operated with a continuously burning pilot flame. Exercise caution when using household products containing combustible vapors.
6. **CAUTION: DO NOT OPERATE THIS APPLIANCE WITH THE GLASS REMOVED, CRACKED OR BROKEN. REPLACEMENT OF THE GLASS SHOULD BE DONE BY A LICENSED OR QUALIFIED SERVICE PERSON. USE ONLY REPLACEMENT GLASS PROVIDED BY YOUR AUTHORIZED JØTUL DEALER. NEVER SUBSTITUTE ANY OTHER TYPE OF GLASS.**

Manual Operation

Familiarize yourself with the controls of the GF 400 DV IPI and be sure that anyone else using the appliance is also familiar with the controls and operation procedures. Always follow the Lighting Instructions on the inside back cover of this manual and also located on the back of the Controls Access Panel.

This appliance is equipped with an ignition device that lights the pilot automatically. Do not try to light the pilot by hand. See fig. 40.

1. Set the Burner switch to OFF.
2. If a wall thermostat is used, set it to the lowest temperature.
3. Connect the stove to 120VAC house current with the power cord supplied.
4. **Set the Pilot Mode:**
 - **CPI is for continuous pilot operation** or Proflame 2 remote functionality. **NOTE: The pilot will burn continuously for up to seven (7) days and automatically extinguish if there is no call for heat during that period. The pilot will automatically re-ignite at the next call for heat.**
 - **IPI for intermittent operation.** The pilot will only ignite when there is a call for heat.
5. **Set Burner switch to ON.** The pilot will light.

ON / OFF - Use for manual control of the burner. It remains in the ON position for use with the Proflame 2 remote transmitter. Switch to OFF to manually shut the system down.

T-STAT - Use for optional wall thermostat.
6. Flame intensity can be adjusted by turning the Valve Regulator knob.

WARNING:

READ AND UNDERSTAND ALL OPERATING INSTRUCTIONS BEFORE ATTEMPTING TO OPERATE THIS APPLIANCE. DO NOT ALLOW ANYONE TO OPERATE THIS APPLIANCE WHO HAS NOT READ AND UNDERSTOOD THESE INSTRUCTIONS. KEEP THE REMOTE CONTROL TRANSMITTER WHERE CHILDREN CANNOT REACH IT.

WARNING:

SEVERE INJURY. THIS APPLIANCE CAN BE SET TO OPERATE THERMOSTATICALLY. BE AWARE THAT THE FIREPLACE MAY BE VERY HOT EVEN WHEN THE BURNER IS NOT APPARENTLY OPERATING. KEEP CHILDREN AWAY FROM THE APPLIANCE.

WARNING:

OBSERVE CAUTION NEAR THE GLASS PANEL. THE GLASS MAY SHATTER IF STRUCK BY AN OBJECT. ALWAYS HANDLE THE GLASS PANEL WITH CARE.

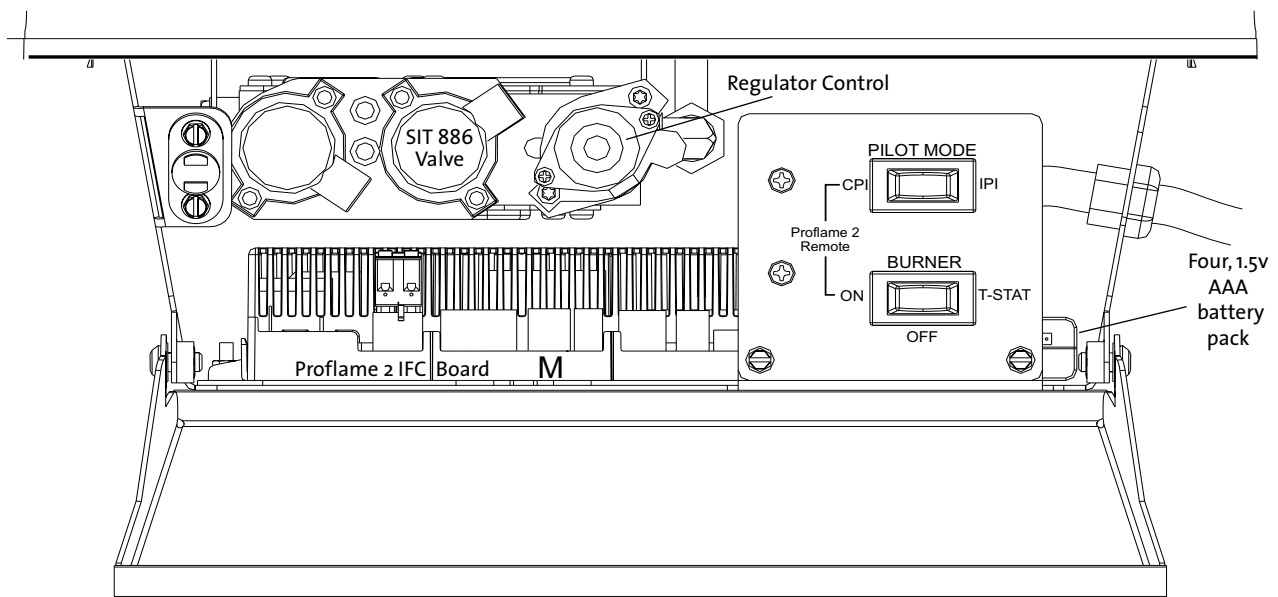

Figure 40. Control Compartment.

Maintenance

Your Jøtul GF 400 DV IPI Sebago components and its venting system should be inspected before use and at least annually by a qualified service technician.

IMPORTANT: ALWAYS TURN OFF THE GAS SUPPLY AND DISCONNECT POWER FROM THE APPLIANCE BEFORE ANY SERVICE WORK IS PERFORMED.

Annual Cleaning

Vent System

The entire vent system, including the chimney, should be inspected and cleaned every year. If the intake and exhaust venting is disassembled for any reason, it should be reassembled and sealed according to the manufacturer's instructions provided at the initial installation.

Burner System

Periodically inspect the firebox, valve compartment, convection airways and optional blower to **BE CERTAIN THAT THE FLOW OF COMBUSTION AND VENTILATION AIR IS UNOBSTRUCTED.**

The firebox and valve compartment should be vacuumed annually to remove any dust and debris. Use a soft brush attachment and handle the logs carefully as they are fragile. Vacuum more frequently if there are pets in the home.

The pilot assembly should be inspected and cleaned annually by a qualified technician. Any component showing corrosion should be replaced.

Safety Barrier Screen

The integrated, Invisimesh® safety screen, located in front of the door glass, should be periodically cleaned to remove dust, lint, and other air-borne debris. Over time, and with continuous exposure to heat, these materials can contribute to screen hue variations.

Open the front door and clean both sides of the screen using a fine, soft bristle brush or vacuum attachment. **AVOID DAMAGING THE SCREEN. APPLY ONLY VERY GENTLE PRESSURE.**

Glass Care

Clean the glass only when necessary. Wipe the surface with a clean, dampened, soft cloth. Follow with a dry, soft towel. Take care not to scratch the glass surface.

WARNING:
DO NOT USE ABRASIVE CLEANERS ON THE GLASS.
NEVER CLEAN THE GLASS WHEN IT IS HOT.
DO NOT USE AMMONIA-BASED CLEANING SOLUTIONS .

NOTE: INSPECT THE GLASS SURFACE FOR SCRATCHES AS THESE CAN WEAKEN THE PANEL TENSILE STRENGTH. REPLACE THE PANEL IF ANY SCRATCHES ARE FOUND. REPLACEMENT SHOULD BE DONE ONLY BY A QUALIFIED TECHNICIAN USING ONLY JOTUL PART NO. 155599.

Gasket Inspection

It is important that the glass gasket be inspected at least annually. Examine the ribbon gasket for signs of deterioration and make sure the gasket has a positive seal. Replace the gasket if necessary. Refer to the replacement parts list on page 35.

Glass Panel or Gasket Replacement

1. Remove the top plate and release the two Glass Frame Latches. Pull each latch handle forward forward to disengage the latch from the notches in the glass frame. Lift the glass frame up off of the stove and lay the assembly on a blanket or towel.
2. Use a screwdriver or small pliers to pry the four retainer tabs up just enough to release the glass panel. See fig. 41.
3. Remove the old gasket material.
4. Wrap the new gasketing material evenly around the edge of the glass, peeling back the protective strip to expose the adhesive as you go. See fig. 42. Press the adhesive side down onto the glass surface. Do not stretch the gasket.
5. Place the gasketed glass within the frame and carefully bend each of the retainer tabs back to secure the glass in the frame. The replacement glass kit 155599 includes 4 compression clips for use in case a tab should break.



Figure 41. Bend the retainer tabs back enough to release the glass panel.

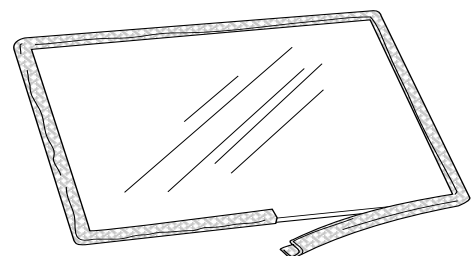

Figure 42. Wrap the gasket around the glass panel.

Accessories

Premium Upgrade Kits

#157498 - NG

#157499 - LP

Kit Contents:

- Flame Control (LP or NG)
- Accent Lamp Kit
- Blower Kit with Multifunction Remote

READ THESE INSTRUCTIONS BEFORE BEGINNING THE INSTALLATION. SEE PAGES 29-32 FOR REMOTE CONTROL OPERATION.

WARNING:
DISCONNECT THE POWER SUPPLY AND TURN OFF THE MAIN GAS SUPPLY TO THE STOVE BEFORE INSTALLING REMOTE CONTROLLED ACCESSORIES.

Flame Control Installation

1. Using a Torx T-20 screwdriver, remove the two screws from the front of the manual regulator and remove those components as shown in fig. 43.
2. Confirm the appropriate fuel type by the label on the Flame Control motor. Install the motor using the new screws included with the kit.
3. Connect the wire harness to terminal (M) on the front side of the IFC board.
4. If appropriate, follow the instructions for fuel conversion beginning on page 16.

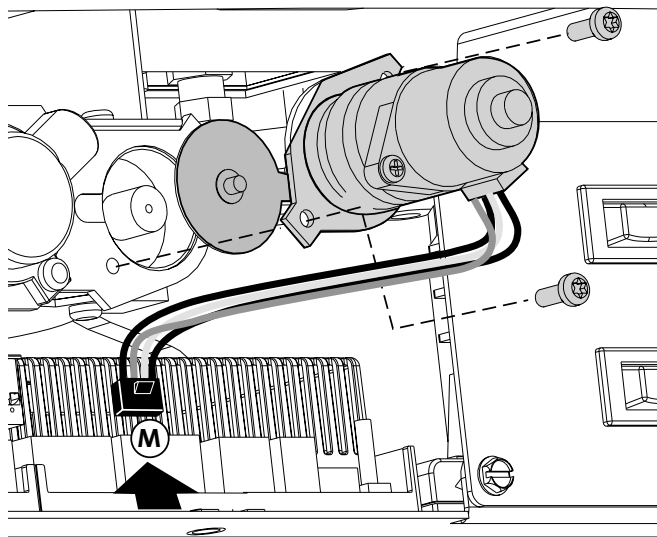

Figure 43. Flame Control Motor installation.

Accent Lamp

Contents:

1. Lamp Box Assembly w/ harness
2. Lens
3. Gasket
4. Light Deflector Plate

Tools Required:

- 10 mm wrench
- Safety goggles
- Work gloves

1. Remove the stove top plate.
2. Remove the two flanged hex head bolts (A), nuts (B) and cover plate from the Relief Panel using a 10 mm socket or wrench. See fig. 44.
3. Position the Gasket, Lens, and Lamp Box on the top of the Relief Panel using the two bolts (A) previously removed.
4. Inside the firebox, attach the Light Deflector plate to the bolts on the underside of the Relief Panel using the nuts (B) previously removed.
5. Route the controls wire harness over and down between the heat shield and the left cast iron side. Connect the harness to the (L) terminal on the rear of IFC board. See figs. 45, 46, page 28.

See Remote Control operation instructions on pages 29-32.

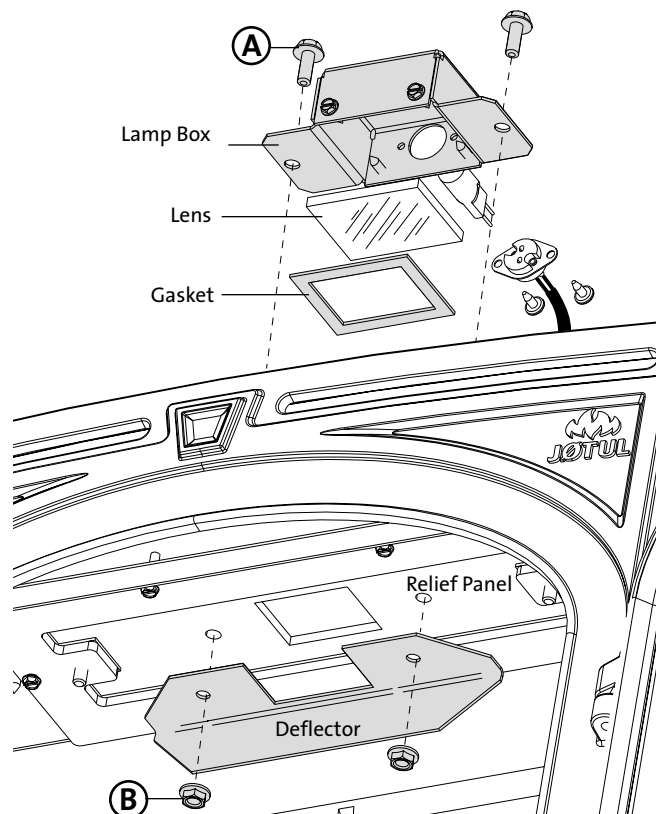

Figure 44. Accent Lamp installation.

Variable Speed Blower #157470

■ This blower must be electrically grounded in accordance with local codes or, in the absence of local codes, with the current ANSI/NFPA 70, National Electrical Code or CSA C22.1-Canadian Electrical Code.

Be certain the blower motor is securely fastened to the mounting frame on the stove.

■ Always disconnect the power supply to the stove before performing any service on the blower.

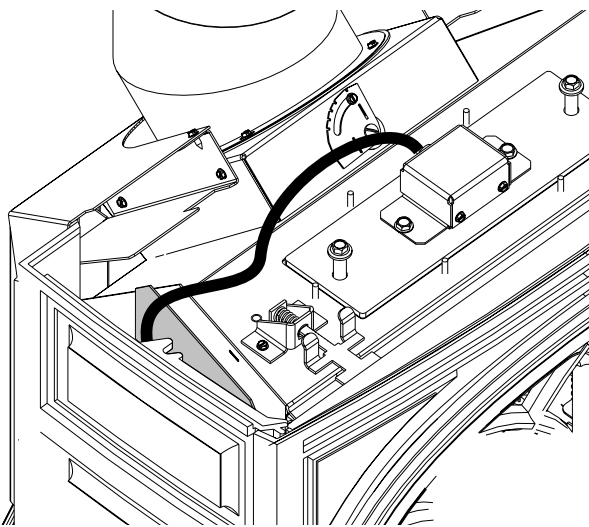

Figure 45. Route the lamp harness between the heat shield and the cast iron side panel.

Contents

1. Blower
2. Mounting Bracket
3. IFC wire harness
4. M6 x 12 hex head flange bolts, 2
5. M6 x 12 wing screw
6. Wire tie

Tools Required

- 10 mm wrench
- Safety goggles
- Work gloves

1. Disconnect the power supply from the stove.
2. Orient the Blower Bracket (fig. 46, #2) as shown and securely attach it to the stove using the two M6 flange head hex bolts (#4).
3. Install the Blower (#1) with the duct openings oriented up and forward as shown. Secure the blower to the bracket with the wing screw (#5).
4. Connect the Blower wire harness to terminal (B) on the IFC board as shown in fig. 50. Use the wire tie provided to take up any extra slack in the harness.
5. Reconnect power supply to the stove.

See Remote Control initialization and operation instructions on pages 29-32.

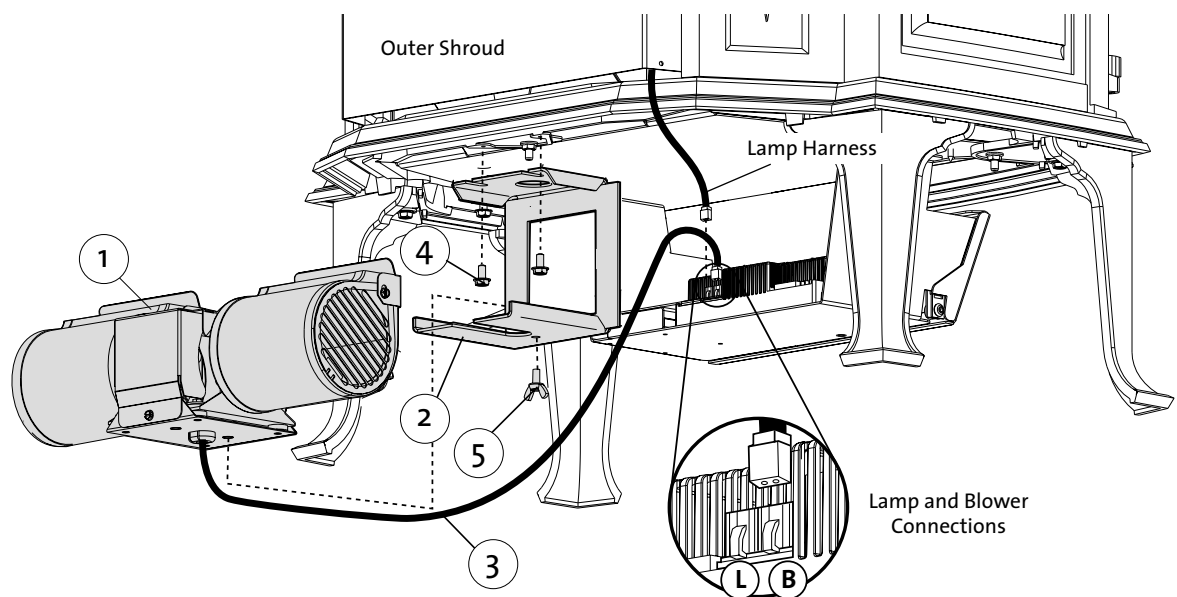

Figure 46. 157470 Blower Kit Components used for GF 400 DV IPI Sebago.

Proflame 2 Remote Control

Features Overview

The Proflame 2 Integrated Fireplace Control (IFC) incorporates electronic remote control of the Jøtul GF 400 DV IPI features. It is configured to control the on/off operation both manually and thermostatically, with standard and “Smart” thermostat features. It will also control flame modulation, fan power and speed, accent lighting function and level.

The burner utilizes an **IPI system (Intermittent Pilot Ignition)** and may also be switched to keep the pilot lit continuously if desired (**CPI - Continuous Pilot Ignition**). **CPI NOTE:** The pilot light will automatically extinguish after 7 days. It will automatically re-ignite at the next call for heat, either manually or thermostatically.

If left under thermostatic control, the unit will switch to IPI mode allowing the pilot to ignite only when there is a call for heat.

Power is provided to the IFC by 120V house current. In the event of a power failure, burner operation is backed-up by a 6V battery pack (four, 1.5v AA).

Remote Control Transmitter

The remote transmitter has all controls available on its face for reliable, ease of use. It gives room temperature readout, set temperature readout, all function abilities as well as childproof lockout and low battery indicator. Icons appear on the screen indicating which mode of operation you are controlling. The four button controls are easy to learn and simple to operate. The transmitter is powered by 3, 1.5V AAA batteries.

Remote Control Receiver

The receiver is integrated with the IFC board which is located within the valve compartment.

Integrated Fireplace Control (IFC)

The IFC is the electrical heart of the system. It provides power to all components and converts to 6.5v DC in the event of power failure. The IFC sends power to the fan system and the accent light. When no line power is available these features will not operate, however the battery back-up allows remote control of burner operation.

Sit 885 Modulating Valve

This valve has the ability to be stepped down in six increments between high and low. It can be done manually or by setting the remote control to the Smart thermostat modulation mode. Automatic modulation means that as the room temperature approaches the

limit set for shut down, the valve gradually decreases or “steps-down” the fire intensity. Conversely, as room temperature cools, the valve gradually increases flame intensity.

The overall result is more comfortable, even heating that minimizes temperature peaks and valleys.

Pilot Assembly

The pilot contains a pilot hood, igniter, and a flame sensor. The igniter sends a spark to the pilot hood which lights the gas. The sensor is then engulfed by the pilot flame, flame rectification occurs and the unit remains lit. If rectification does not occur, the main burner will not

WARNING:

READ AND UNDERSTAND ALL OPERATING INSTRUCTIONS BEFORE ATTEMPTING TO OPERATE THIS APPLIANCE. DO NOT ALLOW ANYONE TO OPERATE THIS APPLIANCE WHO HAS NOT READ AND UNDERSTOOD THESE INSTRUCTIONS. KEEP THE REMOTE CONTROL TRANSMITTER WHERE CHILDREN CANNOT REACH IT.

WARNING:

SEVERE INJURY. THIS APPLIANCE CAN BE SET TO OPERATE THERMOSTATICALLY. BE AWARE THAT THE FIREPLACE MAY BE VERY HOT EVEN WHEN THE BURNER IS NOT APPARENTLY OPERATING. KEEP CHILDREN AWAY FROM THE APPLIANCE.

WARNING:

FIRE HAZARD. CAN CAUSE SEVERE INJURY OR DEATH. THE APPLIANCE CAN TURN ON SUDDENLY. KEEP AWAY FROM THE APPLIANCE BURNER WHEN OPERATING THE REMOTE SYSTEM.

WARNING:

OBSERVE CAUTION NEAR THE GLASS PANEL. THE GLASS MAY SHATTER IF STRUCK BY AN OBJECT. ALWAYS HANDLE THE GLASS PANEL WITH CARE.

ATTENTION:

- **TURN “OFF” MAIN GAS SUPPLY PRIOR TO REMOVING OR REPLACING BATTERIES.**
- **IN CASE OF REMOTE CONTROL MALFUNCTION, TURN OFF THE IFC DEVICE USING THE MAIN “ON/OFF” SWITCH.**
- **FOR INSTALLATION/MAINTENANCE SWITCH “OFF” THE IFC DEVICE BY DISCONNECTING THE MAIN POWER SUPPLY PLUG.**

Control Functions

Pilot Mode

Set the stove switch to CPI mode for Proflame 2 remote control. The IPI/CPI functionality will be controlled by the remote transmitter.

Burner Control

Set the stove burner switch to ON for Proflame 2 remote control.

OFF - Turns off both remote and manual burner functionality. Switch to OFF when the stove will not be used for an extended period of time.

Remote Transmitter

The Transmitter features a simple button layout and informative display screen. See figs. 51-52.

LCD DISPLAY - graphically indicates temperature settings and status of the Thermostat, Burner, Fan, and Accent Lamp.

ON / OFF Key - controls Burner, Fan, and Lamp functions.

THERMOSTAT Key - Used to set either Manual or Thermostatic Control and index through thermostatic functions.

UP / DOWN Arrow Key - Selects thermostat temperature range, fan speed, and flame height.

MODE Key - used to select the component to be controlled: CPI/IPI, Burner, Fan, and Accent Lamp.

The Wall Mount Bracket can be used for convenient Transmitter storage.

Initializing the System

1. Press the Controls Access Door to release its magnetic catch and swing the panel down. Switch the Burner to OFF. See fig. 40, pg. 25.
2. Install three AAA batteries into the Transmitter.
3. Press the black (or red) button on the right front corner of the IFC board, just behind the stove switch plate. The board will “beep” three times and a yellow LED indicates a 10-second synchronization time limit.
4. Within the 10-second time frame, push the ON button on the Transmitter. The IFC will “beep” four times to indicate that it has acknowledged the transmitter command and sets to the particular code of that Transmitter.
5. **To return to full Manual functionality**, hold the black initialization button down until it “beeps”.
6. **After initialization, the burner switch must be placed in the ON position and Pilot Mode switch placed in CPI.** The remote can then be used to control the burner.

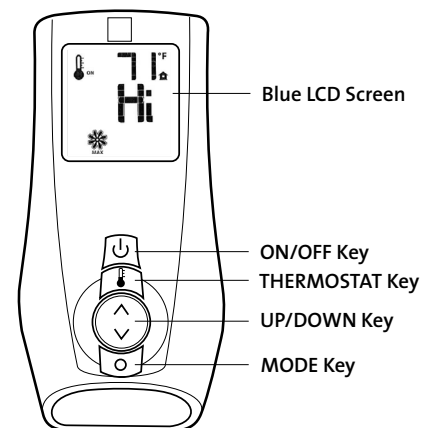

Figure 47. Remote transmitter function keys.

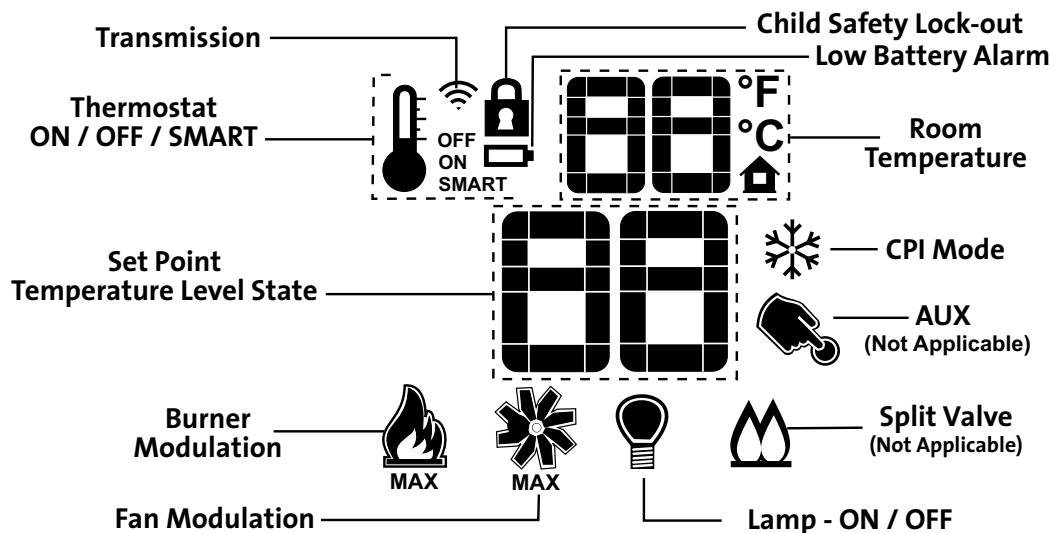

Figure 48. Remote transmitter display data.

Remote Transmitter Controls

Temperature Indication Display

■ With the transmitter in the OFF position, press the Thermostat Key and the Mode Key at the same time. The display screen will show the current room temperature cycling between Fahrenheit and Celsius indicators each time the keys are pressed simultaneously. See fig.49.

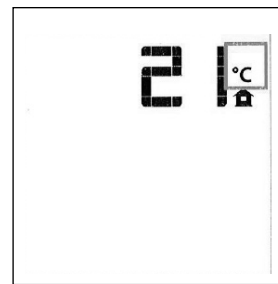
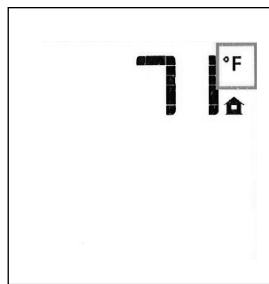

Figure 49. Room temperature readings

Pilot Mode

■ With the transmitter in the OFF position, press the transmitter Mode key - IPI is the default mode. Fig. 50. Press the Up arrow to index to the CPI icon and activate the Continuous Pilot Ignition mode. Fig. 51. Pressing the Down Arrow Key will return to Intermittent Pilot Ignition. A single “beep” will confirm reception of the command.

NOTE: Setting the stove Pilot Mode switch to IPI will disable remote IPI/CPI switching.

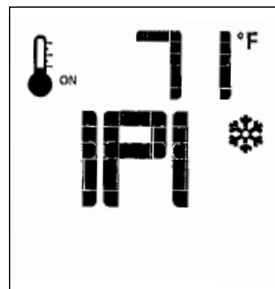

Figure 50. IPI is the default position.

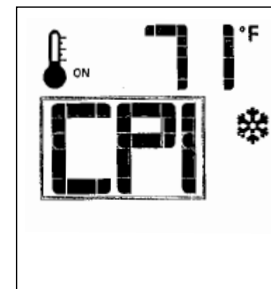

Figure 51. CPI ON.

Turn on the Burner

■ Press the ON/OFF Key on the Transmitter.

The display will show all the active icons. At the same time, the Receiver will activate the Pilot Ignitor. First the pilot will ignite, followed shortly by the burner. A single “beep” from the Receiver will confirm reception of the command.

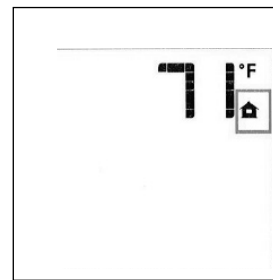

Figure 52. Burner shut-down

Turn off the Burner

■ Press the ON/OFF Key. The display will show only the room temperature and icon. At the same time, the Receiver will deactivate the call for heat and the burner will shut down. Fig. 53. A single “beep” from the Receiver will confirm reception of the command.

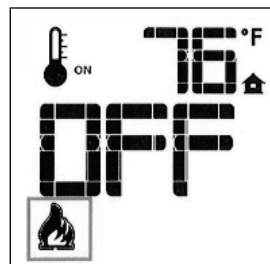

Figure 53. Burner OFF.

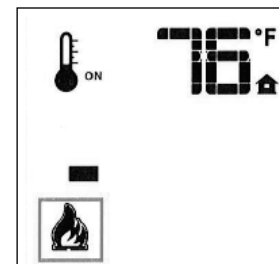

Figure 54. Flame Level 1.

Remote Burner Control

There are six flame levels available.

■ With the system ON, and the burner flame level at maximum, press the Down Arrow Key once to reduce the flame height by one step. Each time the Down Key is pressed, the flame will step down until the burner is finally turned off. Fig. 53.

■ The Up Arrow Key will increase the flame height each time it is pressed. If the Up Arrow Key is pressed while the system is on but the flame is off, the flame will come on in the High position as in figs. 54-56. A single “beep” will confirm reception of the command.

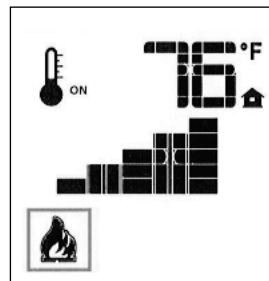

Figure 55. Flame Level 5.

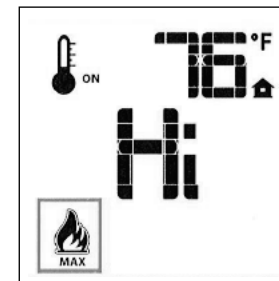

Figure 56. Flame Level 6.

Room Thermostat (Transmitter Operation)

The Remote Control can operate as a room thermostat. The thermostat can be set to a desired temperature to control the comfort level in a room.

- To activate this function, press the Thermostat Key. The display will indicate that the room thermostat is “ON” and the current Set Temperature is now displayed. Fig. 57.
- To adjust the Set Temperature, press the Up or Down Arrow Keys until the desired Set Temperature is displayed. Fig. 58.

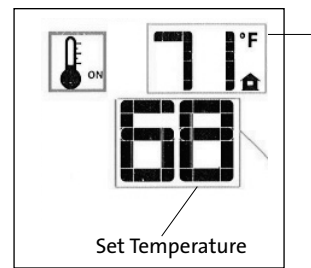

Figure 57. Thermostat ON.

Room Temperature

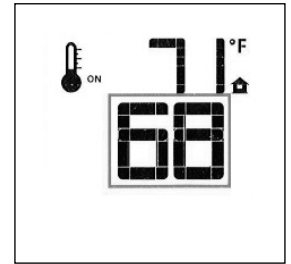

Figure 58. Change Set Temperature.

SMART Thermostat Function

This function adjusts the flame intensity according to the difference in the Set Point temperature and the actual room temperature. As the room temperature gets closer to the Set Point, the Smart Function will modulate flame intensity down.

- To activate this function, press the Thermostat Key until the word “SMART” appears to the right of the thermometer bulb icon. Fig. 59.
- To adjust the temperature, press the Up or Down Arrow Keys until the desired Set Temperature is displayed. Fig. 60.

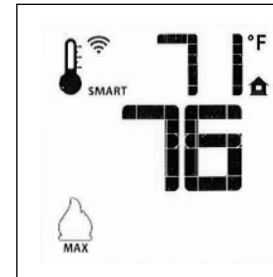

Figure 59. Smart Mode

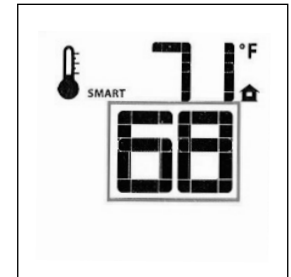

Figure 60. Smart Set Temp.

Fan Control

The fan speed can be adjusted through six settings. To activate this function, press the Mode Key to index to the Fan Control icon. See fig. 61. The fan will not function at all if it is not first set to ON.

- Use the Up/Down Arrow Keys to turn ON, OFF, or adjust the fan speed. Fig. 62. A single “beep” will confirm reception of the command. After a 5 minute interval, the fan will power up to its highest speed and then modulate down to the established fan speed setting. The fan will continue to operate for 12 minutes after the burner is turned off. Manual speed control is not available when the SMART Thermostat is ON.

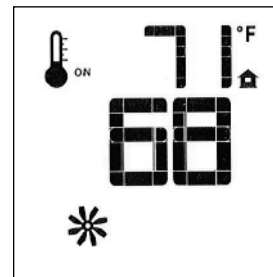

Figure 61. Fan Mode.

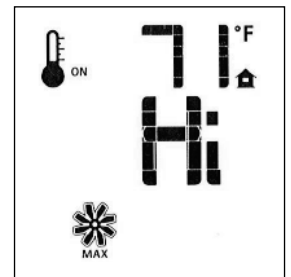

Figure 62. Fan Speed.

Accent Lamp Control

- With the Remote ON, press the Mode Key to index to the Lamp icon. Figs. 63-64.
- Pressing the Up Arrow Key will turn the Lamp ON. Press the arrow keys to adjust the brightness.
- Pressing the Down Arrow Key will turn the Lamp OFF.



Figure 63. Lamp Control.

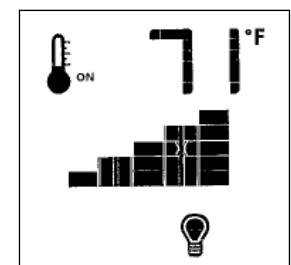

Figure 64. Lamp ON.

Child Safety Lock

This function will lockout the Transmitter to prevent unsupervised operation.

- To activate the Lock, press the Mode key and UP Key at the same time. Fig. 65.
- To de-activate the Lock, press the Mode Key and UP Key at the same time.

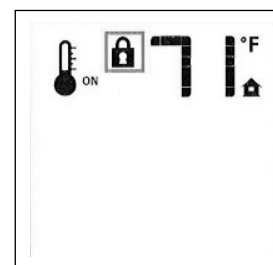

Figure 65. Lock ON.

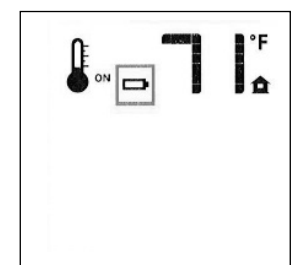

Figure 66. Low Battery.

SIT Proflame 2 IFC Wiring Diagram

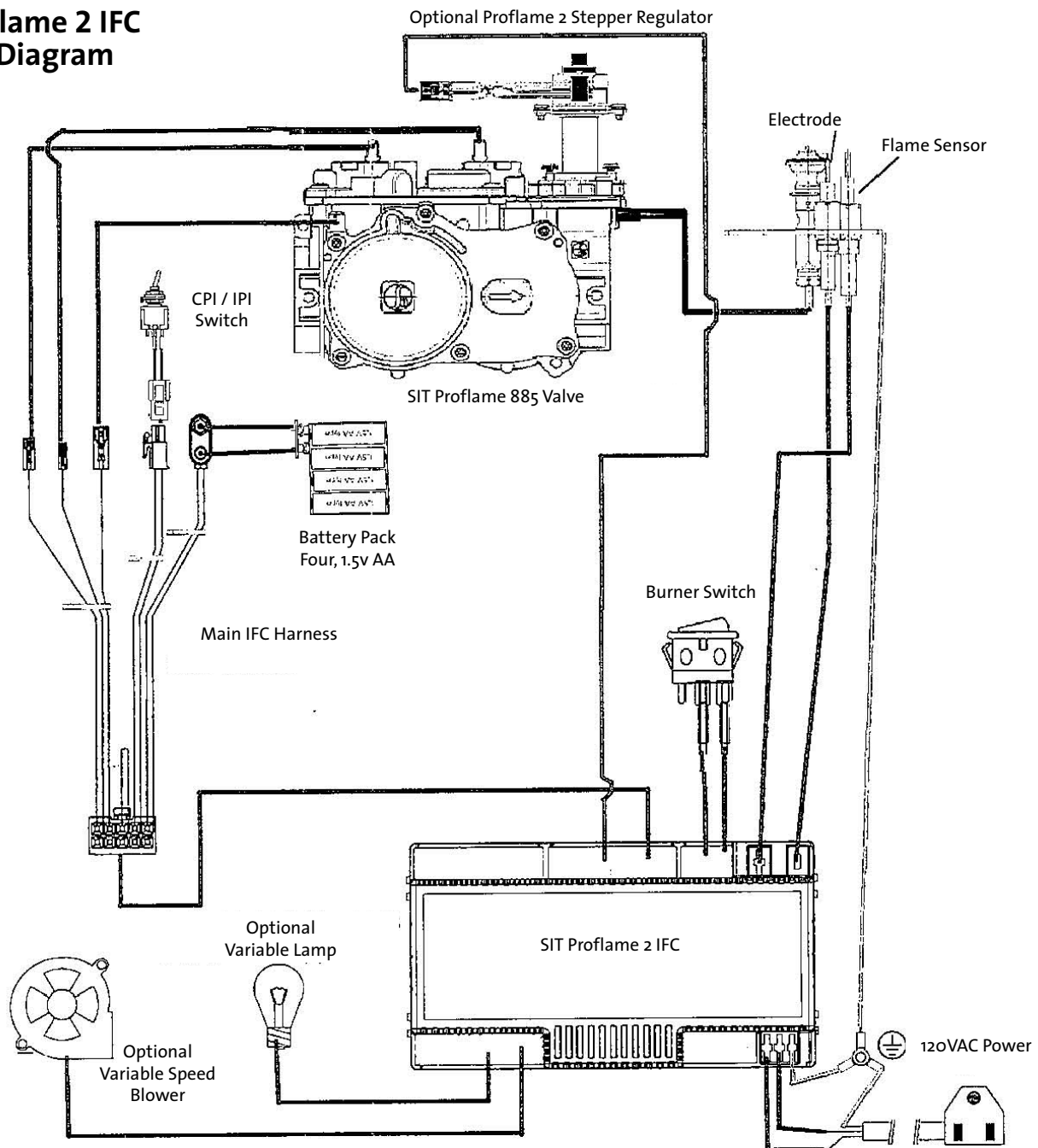

Figure 67. GF 400 DV IPI Sebago with Proflame 2 Premium Remote Control Accessories

IFC Battery Replacement

A red LED on the IFC board indicates low battery power.

1. Switch Burner to OFF and disconnect power to the stove.
2. Access the battery box from behind the right side of the control compartment. See figs. 40 and 69. Disengage it from the hook & loop tape.
3. Install four, 1.5v AA batteries and return box to the compartment.
4. Reconnect power to the stove.

GF 400 DV IPI Sebago

Illustrated Parts Breakdown

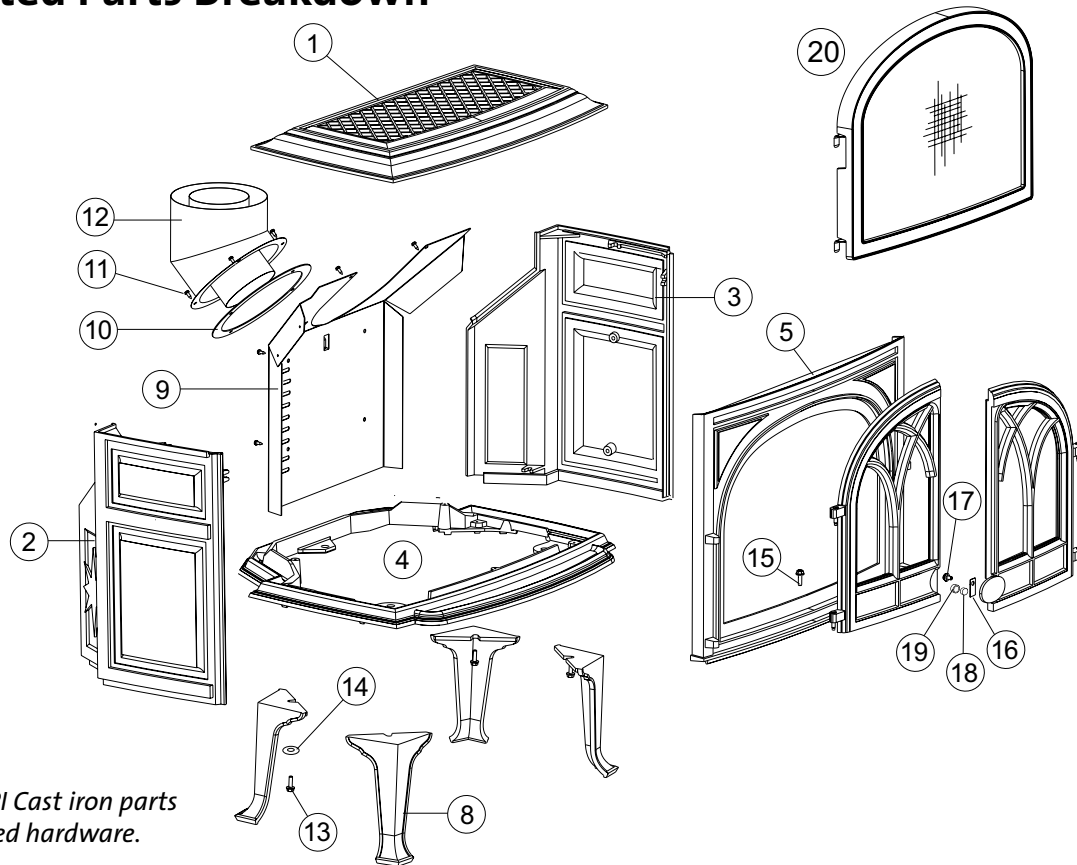

Figure 68.
GF 400 DV IPI Cast iron parts
and associated hardware.

Cast Iron Parts	Matte Black Paint	Blue Black Enamel	Ivory Enamel	Brown Majolica Enamel	Green Majolica Enamel
1. Top Plate	10396292	10396227	10396229	10396247	10396249
2. Left Side Plate	10391892	10421727	10421729	10421747	10421749
3. Right Side Plate	10391992	10421827	10421829	10421847	10421849
4. Bottom Plate	10396392	10396327	10396329	10396347	10396349
5. Front, Complete	15565492	155660	155672	15565447	n/a
After SN 33402	15772192	157722	155672	157723	10192549
13. Legs, (4)	10192592	10192527	10192529	101925	n/a
20. Safety Barrier	157713				
9. Rear Shroud		22498992			
10. Gasket, Collar		129118			
11. Screw, #8 x 1/2", 4		117917			
12. Vent Collar, 4/6		129126			
13. Bolt, M6 x 20, 4		117117			
14. Fender Washer, 4		120004			
15. Bolt, M6 x 20		117117			
16. Magnet Plate		22498492			
17. Bolt, M6 x10		9962			
18. Magnet		225355			
19. Magnet Cover, Neoprene		225338			
Silicone Barrier Bracket Cap, 4		225474			

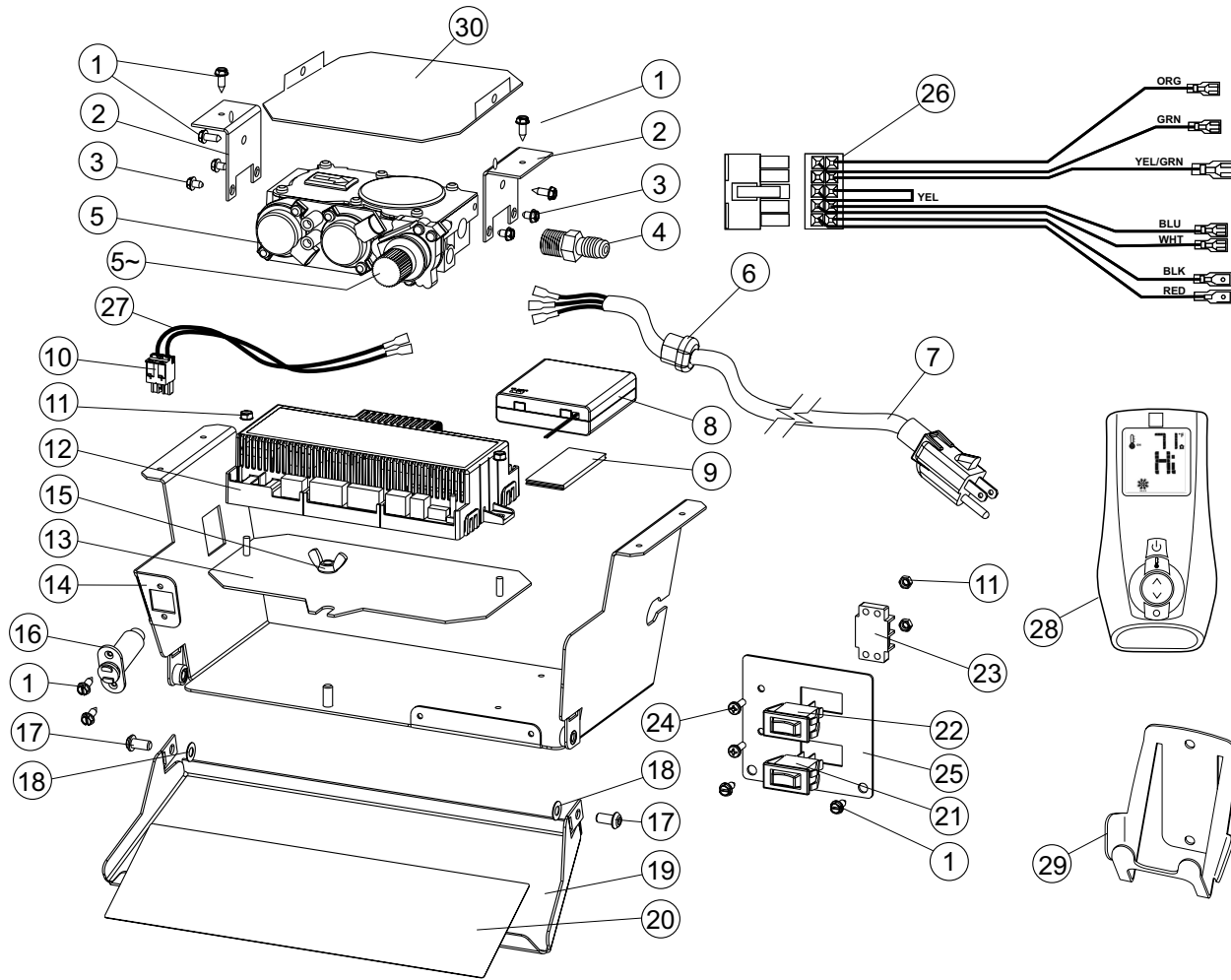

Figure 69.
GF 400 DV IPI Valve Assembly and IFC Components.

No.	Part No.	Description
1.	117917	Screw, #8 x 1/2" SL Blk Oxide
2.	224904	Valve Bracket
3.	118214	Screw, #8x 1/4" Taptite
4.	223215	Adaptor, 3/8" NTP x 3/8" Flare.
5.	224972	Valve w/ NG Regulator, Manual, 50%TD
5x.	224795	Regulator, Manual / LP , 50%TD
	224914	Regulator w/ Stepper Motor / NG, 50% TD
	224915	Regulator w/ Stepper Motor / LP, 50% TD
6.	117951	Wire Strain Relief, Heyco 7P-2 Lg
7.	157492	Power Cord, 18 AWG Grounded - 10 ft.
8.	157265	Replacement Back-up Battery Box (4 AA)
9.	118257	Hook & Loop Tape, 1" wide - Self adhesive
10.	224794	Connector, 2 Pin / IPI Burner
11.	118055	Kepnut, M4 Ext. Tooth Lockwasher
12.	158030	Proflame 2 IFC Control Board, (POD)
13.	224911	IFC Mounting Plate

No.	Part No.	Description
14.	22477092	Control Bracket
15.	117975	Wing Nut, M6 Zinc
16.	224145	Magnetic Catch - Push to open
17.	9962	Bolt, Hex Hd Serr Flng M6 x 10mm
18.	117588	Hinge Washer, M6 - 12mm OD x 6mm ID
19.	22476992	Control Door
20.	224952	Instruction Label, Control Door - GF IPI Series
21.	220703	Rocker Switch, SPDT - Plain
22.	120517	Rocker Switch, SPST - Plain
23.	129154	Terminal Block, 2 Pole - 77 Series
24.	117921	Screw, Pan Hd Ph M4 x 12mm Blk Oxide
25.	224781	Control Faceplate, Silkscreened - GF IPI Series
26.	157493	Replacement IPI Wire Harness - GF IPI Series
27.	157494	Replacement Burner Control Wire Harness
28.	157495	Replacement Multifunction Remote / Black
29.	223951BKP	Replacement Remote Wall Bracket / Black PC
30.	225051	Valve Heat Shield

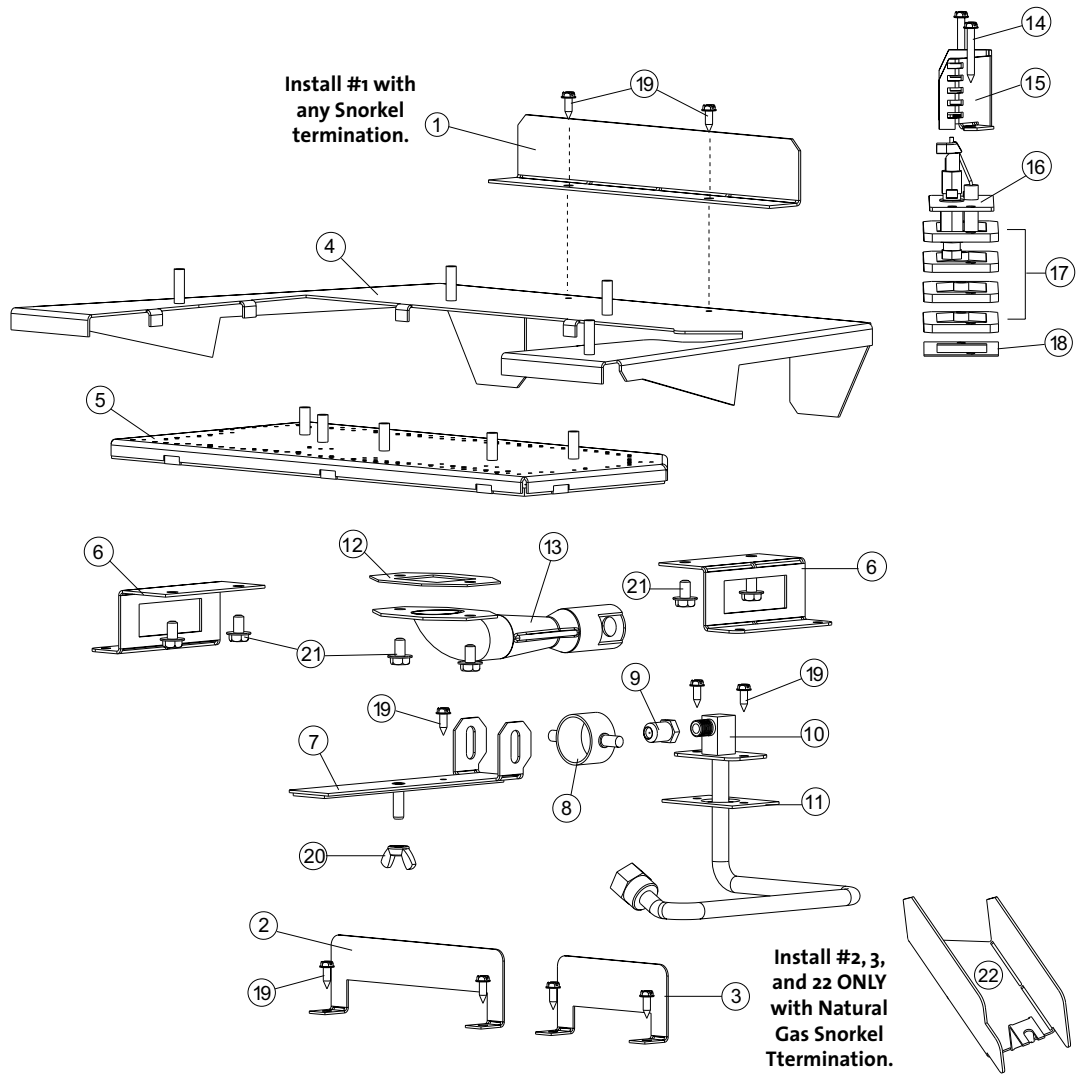

Figure 70.
GF 400 DV IPI Pilot & Burner assembly and associated hardware.

No.	Part No.	Description	No.	Part No.	Description
1.	22503092	Snorkel Plate, Min. Vent	12.		Gasket, Burner Venturi, Steel Burner
2.	22504092	Burner Air Deflector, Long (NG SNORKEL ONLY)	13.		Venturi Tube Weldment
3.	22504192	Burner Air Deflector, Short (NG SNORKEL ONLY)	14.	118205	Screw, Stl Hex Hd Self-drill, #8 x 1.25"
4.	22499692	Burner Skirt	15.	225060	Pilot Shield
5.	157600	Replacement Burner Assy, includes #5, 12, 13, & 21	16.	224785	Pilot, NG/LP, Dual-Fuel Convertible
6.	225022	Burner Support	17.	224791	Spacer, Pilot Assembly
7.	224758	Air Shutter Plate	18.	129670	Gasket, Pilot Assembly
8.	224903	Air Shutter	19.	117917	Screw 8 x 12 1/2 SL Blk Oxide
9.	225042	Orifice, #36 / NG	20.	117975	Nut, Wing M6 Zinc
	045025	Orifice, #52 / LP	21.	9962	Bolt, Hex Cap M6x10 DIN 933 8.8 Ser Flange Blk
10.	223231	Orifice Holder, 12.5" Tube	22.	225059	Pilot Tray (NG SNORKEL TERMINATION ONLY)
11.	222280	Gasket, Drop In Orifice Holder			

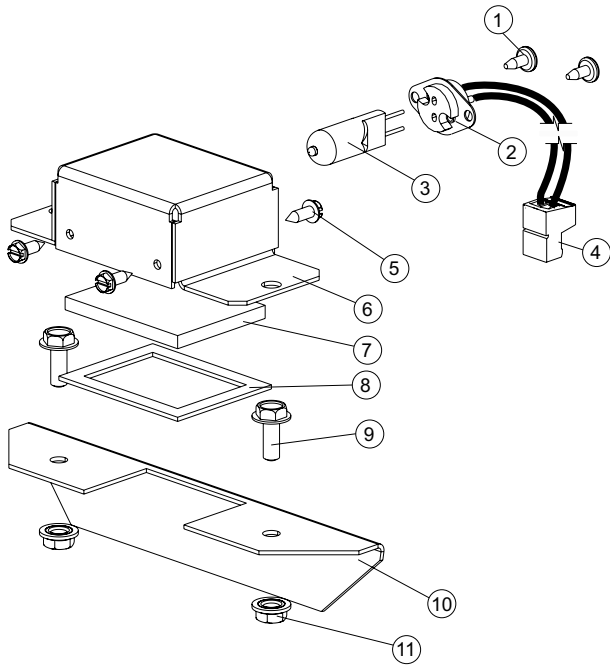

Figure 71.
GF 400 DV IPI Accent Lamp Assembly

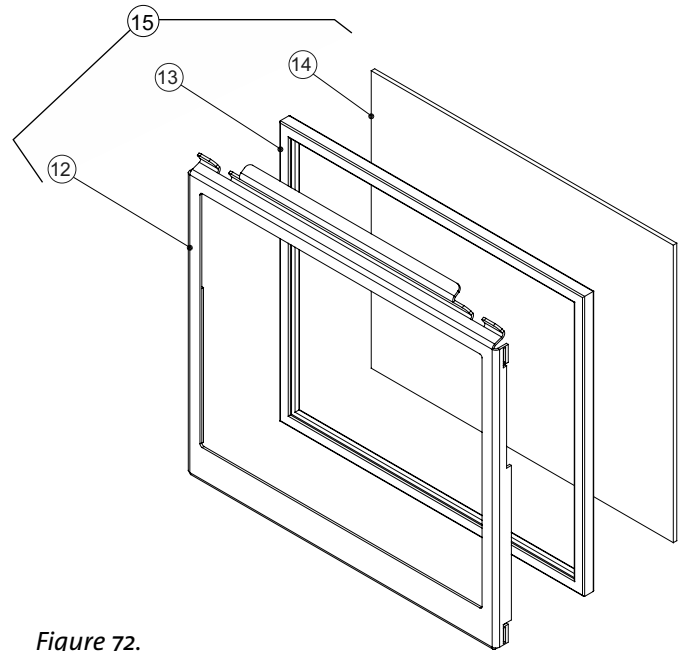

Figure 72.
GF 400 DV IPI Glass Assembly

No.	Part No.	Description
1.	117967	Screw, Pan Head #7 x 3/8 PH Zinc
2.	157601	Replacement Lamp Wire Harness
3.	222943	Light Bulb, 130 Volt, 50 Watt
4.	224796	Connector, 2 pin, IPI Accessories
5.	117917	Screw, 8 x 1/2 SL Blk Oxide
6.	22476392	Light Box, Delay Door Mount
7.	222974	Glass, Ceramic, Light Fixture
8.	222977	Gasket, Light Cover
9.	99625	Bolt, Hex Head Serr Flange M6 x 16 8.8 Blk
10.	22476792	Light Shade, Delay Door Mount
11.	117968	Nut, M6 Serrated Flange Plain
12.	22493592	Glass Frame
13.	129124	Gasket
14.	220576	Glass Panel
15.	155599	Replacement Glass & Gasket, inc. spare clips

Replacement Parts Not Illustrated:

Delay Relief Door Gasket	224764
Brick Panel Retainer	22493192

GF 400 DV IPI Accessories	
Description	Part No.
Premium Upgrade Kit / NG*	157498
Premium Upgrade Kit / LP*	157499
Wall Thermostat	750003
Accent Lamp Kit (requires Multifunction Remote)	157469
Blower Kit with Multifunction Remote	157470
Flame Control Kit / NG (requires Multifunction Remote)	157496
Flame Control Kit / LP (requires Multifunction Remote)	157497
Multifunction Remote Control	157495
Reversible Brick Kit (Antique Red & Brownstone)	157603
Screen	157448
Short Leg Kit / Matte Black	350074
Short Leg Kit / Blue Black Enamel	350075
Short Leg Kit / Ivory Enamel	350117
Short Leg Kit / Brown Majolica Enamel	351174
Short Leg Kit / Green Majolica Enamel	361056
Leg Leveler	156096
Replacement Log Set	157602

* Premium Upgrade Kits include:

- Blower Kit w/ Multifunction Remote
- Accent Lamp Kit
- Flame Control Kit / NG or LP

Appendix

Pilot Tray Installation

FOR USE ONLY ON SNORKEL TERMINATED STOVES USING NATURAL GAS.

1. The Pilot Tray is shipped flat in the Miscellaneous Hardware bag. Bend it up on the perforations as shown in fig. 73.
2. To install the Tray, loosen the screw at the rear of the pilot assembly base enough to engage it with the slot on the tray plate and then retighten the screw.

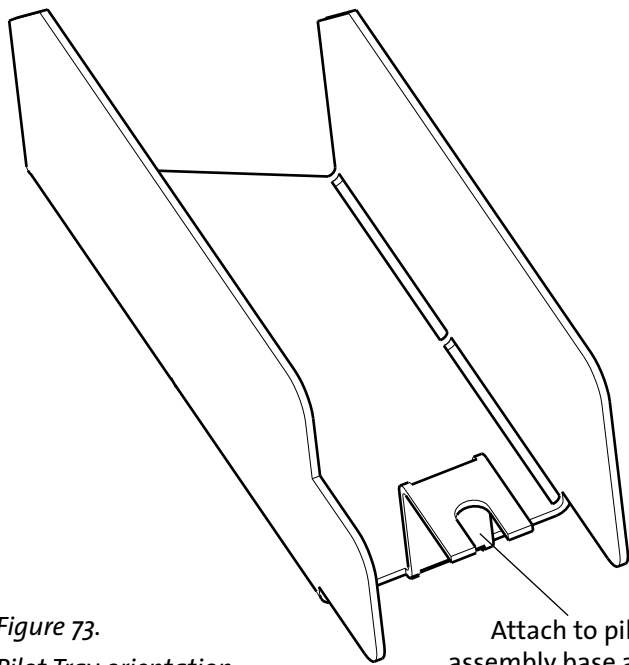

Figure 73.
Pilot Tray orientation.

Attach to pilot
assembly base at slot.

Jøtul Gas Product Warranty

This warranty policy applies to gas products identified by Jøtul, Scan, and Atra trade names, as set forth below.

A. LIMITED FIVE YEAR WARRANTY - Cast Iron, Steel Doors, Surround Components, Firebox:

Jøtul North America Inc. (JØTUL) warrants, to the original retail purchaser, that those components of the Jøtul, Scan, or Atra Gas Stove or Fireplace specified above will be free of defects in material and workmanship for a period of five (5) years from the date of purchase. This warranty is subject to the terms, exclusions and limitations set forth in the following text.

B. LIMITED TWO YEAR WARRANTY - Burner, Burner Treatments, Firebox Panels:

JØTUL warrants, to the original retail purchaser, that those components of the Jøtul, Scan, or Atra Gas Stove or Fireplace specified above will be free of defects in material and workmanship for a period of two (2) years from the date of purchase. This warranty is subject to the terms, exclusions, and limitations set forth in the following text.

C. LIMITED TWO YEAR WARRANTY - Enamel Finish:

JØTUL warrants, to the original retail purchaser, the enamel finish on cast iron components of the Jøtul Stove or Fireplace Insert specified above against peeling or fading for a period of two (2) years from the date of purchase. This warranty is subject to the terms, exclusions and limitations set forth below.

D. LIMITED ONE YEAR WARRANTY - Gas & Electrical Components (controls, plumbing, valve, blower):

JØTUL warrants, to the original retail purchaser, that those components of the Jøtul, Scan, or Atra Gas Stove or Fireplace specified above will be free of defects in material and workmanship for a period of one (1) year from the date of purchase. This warranty is subject to the terms, exclusions, and limitations set forth in the following text.

JØTUL will repair or replace (including parts & labor), at its option, any of the above components determined by JØTUL to be covered by this warranty. You must, at your own expense, arrange to deliver or ship the component to an authorized Jøtul, Scan, or Atra dealer and arrange for pickup or delivery of the component after repairs have been made. If, upon inspection, JØTUL determines that the component is covered by this warranty, the repair or replacement will be made as set forth above. This warranty is not transferable and is extended only to, and is solely for the benefit of, the original retail purchaser of the Jøtul, Scan, or Atra Gas Stove or Fireplace. This paragraph sets forth the sole remedy available under this warranty in the event of any defect in the Jøtul, Scan, or Atra Gas Stove or Fireplace.

The warranty period for any replaced component will be the remaining unexpired portion of the warranty period for the original component. Please retain your dated sales receipt in your records as proof of purchase.

EXCLUSIONS AND LIMITATIONS

NOTICE: This warranty is void if installation or service is performed by someone other than an authorized installer, service agency or gas supplier, or if installation is not in conformance with the installation and operating instructions contained in this owner's manual or local and/or national fire and building regulations. A listing of local authorized installers, service agencies and gas suppliers can be obtained from the National Fireplace Institute at <http://www.nficertified.org/>. This warranty does not cover the following:

1) Repair or replacement of parts that are subject to normal wear and tear during the warranty period or to parts that may require replacement in connection with normal maintenance. These parts include lamp bulbs, gaskets and glass (except to the extent such parts suffer damage from thermal stress).

- 2) Damage due to incorrect installations not in conformance with the installation instructions contained in this owner's manual or local and/or national fire and building regulations.
- 3) Damage due to service performed by an installer, service agency or gas supplier, unless otherwise agreed to in writing by JØTUL.
- 4) Labor or other costs associated with the repair of gas controls, plumbing, burners, log set, or sheet metal firebox beyond the warranty period.
- 5) Damage caused by unauthorized modification, use or repair.
- 6) Damage to enameled surfaces caused by improper operation or misuse, including use that is not in conformance with the operating instructions contained in this owner's manual. Such damage can typically be identified by bubbling, cracking, or discoloration of the enamel finish.
- 7) Costs incurred by travel time and/or loss of service.
- 8) Damage incurred while the Jøtul, Scan, or Atra Gas Stove or Fireplace is in transit.

IN NO EVENT SHALL JØTUL, ITS PARENT COMPANY, SHAREHOLDERS, AFFILIATES, OFFICERS, EMPLOYEES, AGENTS OR REPRESENTATIVES BE LIABLE OR RESPONSIBLE TO YOU FOR ANY SPECIAL, INDIRECT, INCIDENTAL, CONSEQUENTIAL, PUNITIVE OR OTHER SIMILAR DAMAGES, INCLUDING, BUT NOT LIMITED TO, LOST PROFITS, LOST SALES, INJURY TO PERSON OR PROPERTY, OR DAMAGES TO A STRUCTURE OR ITS CONTENTS, ARISING UNDER ANY THEORY OF LAW WHATSOEVER. ALL IMPLIED WARRANTIES, INCLUDING THE IMPLIED WARRANTIES OF MERCHANTABILITY AND FITNESS FOR A PARTICULAR PURPOSE, OR OTHERWISE, ARE LIMITED IN DURATION TO THE LENGTH OF THIS WRITTEN WARRANTY. EXCEPT AS EXPRESSLY SET FORTH HEREIN, JØTUL MAKES NO ORAL, WRITTEN OR OTHER WARRANTY WITH RESPECT TO JØTUL, SCAN OR ATRA GAS STOVES OR FIREPLACES.

Some states do not allow the exclusion or limitation of incidental or consequential damages, or limitations on the length of implied warranties. Therefore, the above exclusions or limitations may not apply to you. This warranty gives you specific legal rights, and you may have other rights, which vary from state to state.

JØTUL reserves the right to discontinue, modify or change the materials used to produce the Jøtul, Scan, or Atra Gas Stove or Fireplace. JØTUL shall have the right to replace any defective component with substitute components determined by JØTUL to be of substantially equal quality and price.

The dollar value of JØTUL's liability for breach of this warranty shall be limited exclusively to the cost of furnishing a replacement component. JØTUL shall not in any event be liable for the cost of labor expended by others in connection with any defective component. Any costs or expenses beyond those expressly assumed by JØTUL under the terms of this warranty shall be the sole responsibility of the owner(s) of the Jøtul, Scan, or Atra Gas Stove or Fireplace.

No dealer, distributor, or other person is authorized to modify, augment, or extend this limited warranty on behalf of JØTUL. NO MODIFICATION OR CHANGE TO THIS WARRANTY WILL BE EFFECTIVE UNLESS IT IS MADE IN A WRITTEN DOCUMENT MANUALLY SIGNED BY AN AUTHORIZED OFFICER OF JØTUL.

An authorized installer may have been provided with certain information related particularly to the Jøtul, Scan, or Atra Gas Stove or Fireplace; however, no authorized installer or other person who may service the appliance is an agent of JØTUL. No inference should be made that JØTUL has tested, certified, or otherwise pronounced any person as qualified to install or service the appliance. JØTUL shall not be liable or otherwise responsible for any error or omission by a person installing or servicing a Jøtul, Scan, or Atra Gas Stove or Fireplace.

If you believe your Jøtul, Scan, or Atra Gas Stove or Fireplace is defective, you should contact your nearest authorized Jøtul, Scan, or Atra dealer, who will process a warranty claim. IN ORDER TO QUALIFY FOR WARRANTY COVERAGE, JØTUL MUST RECEIVE NOTICE OF A POSSIBLE DEFECT WITHIN SIXTY (60) DAYS OF THE DATE THE DEFECT IS FIRST DISCOVERED, OR REASONABLY COULD HAVE BEEN DISCOVERED.

This warranty is given by Jøtul North America, Inc.,
55 Hutcherson Drive, Gorham, Maine 04038 USA

LIGHTING INSTRUCTIONS

FOR YOUR SAFETY, READ BEFORE LIGHTING.

WARNING:

IF YOU DO NOT FOLLOW THESE INSTRUCTIONS EXACTLY, A FIRE OR EXPLOSION MAY RESULT CAUSING PROPERTY DAMAGE, PERSONAL INJURY, OR LOSS OF LIFE.

- A.** This appliance is equipped with an ignition device which automatically lights the pilot. **Do Not** try to light the pilot by hand.
- B. BEFORE LIGHTING**, smell all around the appliance area for gas.
Be sure to smell next to the floor because some gas is heavier than air and will settle to the floor.
- WHAT TO DO IF YOU SMELL GAS:**
- Extinguish any open flame
 - Open windows.
 - Do not light this or any other appliance.
 - Do not touch any electrical switches.
 - Do not use any phone in your building.
 - Immediately call your gas supplier from a neighbor's phone.
- If your gas supplier cannot be reached, call the fire department.
- C.** Use only your hand to turn the gas control knob. Never use tools. If the knob will not turn by hand, do not try to force it or repair it.
Call a qualified technician. Force or attempted repair may result in a fire or explosion.
- D.** Do not use this appliance if any part has been under water. Immediately call a qualified service technician to inspect the appliance and to replace any part of the control system and any gas control which has been under water.

OPERATING INSTRUCTIONS

1. STOP! Read the safety information above.
2. Set the thermostat, if equipped, to the lowest setting.
3. Set the Burner switch to the "OFF" position.
4. This appliance is equipped with an ignition device which automatically lights the pilot. Do not try to light the pilot by hand.
5. Wait five (5) minutes to clear out any gas. Then smell for gas, including near the floor.
6. Set the Pilot Mode switch to CPI for continuous operation. The pilot will light. Set Pilot to IPI for thermostatic operation. The pilot will light when there is a call for heat.
7. Set the Burner switch to the "ON" or "T-STAT" position.

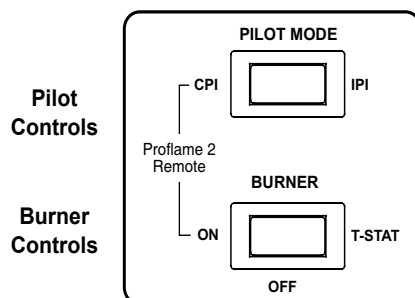

If you smell gas, STOP! Follow "B" in the safety information above on this label. If you do not smell gas, go to the next step.

PILOT ASSEMBLY

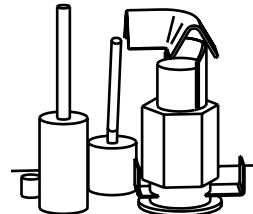

8. Set the thermostat to the desired setting to light the burner. If the appliance will not operate, follow the instructions "To Turn Off Gas To Appliance", and call your service technician or gas supplier.

TO TURN OFF GAS TO THE APPLIANCE

1. Set the thermostat to the lowest setting.
2. Turn off all electric power to the appliance if service is to be performed.
3. Set the Burner switch to the "OFF" position.
4. Close control access door.

February 2020
139548_J

This appliance must be installed in conformance with local and national building regulations. Before beginning the installation, it is important that these instructions be carefully read and understood. Jøtul maintains a policy of continual product development. Consequently, products may differ in specification, color or type of accessories from those illustrated or described in various publications.



Jøtul North America
55 Hutcherson Dr.
Gorham, Maine 04038-2634

Jøtul ASA
P.O. Box 1411
N-1602 Fredrikstad, Norway